



City of San Leandro

Meeting Date: April 1, 2013

Staff Report

File Number: 13-126

Agenda Section: CONSENT CALENDAR

Agenda Number: 8.C.

TO: City Council

FROM: Chris Zapata
City Manager

BY: Uchenna Udemezue
Engineering & Transportation Director

FINANCE REVIEW: David Baum
Finance Director

TITLE: Staff Report for Resolution Approving and Authorizing the City Manager to Execute Two Agreements with the San Leandro Chamber of Commerce: 1) a Property Exchange and Indemnity Agreement with One and Only Right of First Offer for the City's Office Space Located at 120 Estudillo Avenue in the New Downtown Garage in Exchange for the Chamber's Parcel at 262 Davis Street and 2) a Reciprocal Easement Agreement and Declaration of Covenants, Conditions, and Restrictions for the Office Space

SUMMARY AND RECOMMENDATIONS

Staff recommends that the City Council approve and authorize the City Manager to execute two agreements with the Chamber of Commerce. The first is a property exchange agreement of the Chamber of Commerce's property at 262 Davis Street (APN: 075-0001-008-02) and the new office parcel created at 120 Estudillo Avenue (the new downtown parking garage). The second is an easement agreement and covenants, conditions, and restrictions (CC&Rs) that will address issues concerning the 120 Estudillo Avenue office space within the parking garage (Garage).

BACKGROUND

In July 2005, the former Redevelopment Agency ("Agency") began discussions with the San Leandro Chamber of Commerce regarding Agency acquisition of 262 Davis Street ("Chamber Property") in San Leandro. The Chamber Property was identified as a priority because of its location in the downtown area, adjacent to other Agency-owned property. The Property and the adjoining parcels were the focus of a specific planning effort to redevelop the entire block and create Town Hall Square. Preliminary design schematics were for a mixed use development (retail on the ground floor and residential above) including the closure of Hays Street.

The Chamber was open to selling the Property; however, there were specific criteria that needed to be met. The main criterion for the Chamber was the ability to relocate to another downtown location without significantly increasing costs.

The Agency's and the Chamber's negotiations culminated in a Lease with Option to Purchase Agreement dated September 2, 2008. Following are the major deal points of that agreement:

- The Agency would lease, with an option to purchase, the Chamber Property for a period of up to three (3) years at \$2,900 per month.
- The Agency agreed to build the Chamber a 2,000 square foot Class B office condominium on the ground level of 120 Estudillo Avenue in the new parking garage that was to be built. The City, as owner of the garage, would charge no condominium association fees. Three parking spaces in the garage were to be made available to the Chamber at no charge. The office space would have separate utilities, such as water, electricity, gas, communications, and sewer. The Chamber would be responsible for user fees and the maintenance and repair of all utilities.
- The Chamber agreed to allow the Agency to demolish the office building on its Property for temporary parking. The Agency paid all costs associated with the demolition.
- The Chamber elected to receive \$10,000 in lieu of making any and all relocation claims and receiving payment for any and all such benefits to which the Chamber may have been entitled when it relocated its offices from 262 Davis Street.
- Upon issuance of an occupancy permit, a concurrent escrow closing would occur to exchange the Chamber Property for the Agency office condominium in the garage. The Agency agreed to pay the Chamber an additional \$10,000 to cover costs associated with the relocation and re-establishment of its offices at the garage.
- The 2008 agreement was for a term of three years, with a two (2) year option to extend should the City not complete the garage within three years.

Analysis

When the 2008 agreement was reached, it was envisioned that the Chamber of Commerce would have an office condominium within the garage structure. As the garage was built, staff determined that rather than a condominium, a Vertical Parcel Map splitting off the Chamber's office from the remainder of the parking structure with a reciprocal easement agreement between the two parties to address utilities, parking, and access would be a less cumbersome approach. No association would need to be formed nor assessments levied and funded. The City's property and the Chamber's office space would be identified as separate lots on the Parcel Map. The Chamber agreed to this approach.

The Reciprocal Easement Agreement and Declaration of Covenants, Conditions, and Restrictions outlines all of the rights and responsibilities of the City and the Chamber as it relates to the Office Parcel, including details about use, maintenance, and access. Use: Included in the terms of use are allowances and restrictions concerning signage, accommodating repairs or improvements to each parcel, and the proper use of the parcels and easement areas. Maintenance: Each party is expected to maintain its parcel and to adhere to certain standards, including those for cleanliness, storage, and exterior appearance. Access: The City grants the Chamber easements for access to all public areas within the Garage and for its Waste Room, Mechanical Equipment Area, and Parking spaces. Each party is granted Utility and Service Easements for its Utility Facilities.

The elimination of redevelopment agencies by the State impacted the ability of the City/Agency to exchange the property under the 2008 Lease with Option to Purchase Agreement. The new property exchange agreement allows for that property exchange as envisioned. It includes the main provisions of the 2008 agreement. The Property Exchange and Indemnity Agreement with One and Only Right of First Offer transfers ownership of the Chamber Property at 262 Davis Street to the City and in exchange transfers ownership of the Office Parcel at the garage to the Chamber. The agreement is an even exchange, meaning that no money is being exchanged, just the real property. The Chamber will be paid the \$10,000 promised in the 2008 agreement for its relocation costs to the Garage. The agreement also gives the City the right to make one offer for the parcel if the Chamber desires to sell it. If the Chamber refuses to accept the City's offer, this right is extinguished. It is the Chamber's desire to move into the space as soon as the Parcel Map is recorded, and these two agreements are subsequently recorded. The Chamber will not be moving in prior to that.

Current Agency Policies

The Transit Oriented Development Strategy adopted by the City Council in September 2007 identified development of Town Hall Square into a mixed use development as a priority.

Previous Actions

On September 2, 2008, by Resolution No. 2008-023 RDA, the Agency approved the Lease with Option to Purchase Agreement.

Environmental Review

Acquisition of the Chamber property is exempt from CEQA pursuant to Section 15061(b)(3) which applies to "projects where it can be seen with certainty that there is no possibility that the activity in question may have a significant effect on the environment." The potential development of the site was covered under the Downtown San Leandro TOD Strategy at the Program EIR level. Specific development applications for the site will be reviewed in the future to determine if the Program EIR adequately addressed those potential impacts.

ATTACHMENTS

None.

PREPARED BY: Tara Peterson, Administrative Services Manager, Engineering & Transportation Department



City of San Leandro

Meeting Date: April 1, 2013

Resolution - Council

File Number: 13-127

Agenda Section: CONSENT CALENDAR

Agenda Number:

TO: City Council

FROM: Chris Zapata
City Manager

BY: Uchenna Udemezue
Engineering & Transportation Director

FINANCE REVIEW: David Baum
Finance Director

TITLE: ADOPT: Resolution Approving and Authorizing the City Manager to Execute Two Agreements with the San Leandro Chamber of Commerce: 1) A Property Exchange and Indemnity Agreement with One Right of First Offer for the City's Office Space Located at 120 Estudillo Avenue in the New Downtown Parking Garage in Exchange for the Chamber's Parcel at 262 Davis Street and 2) a Reciprocal Easement Agreement and Declaration of Covenants, Conditions, and Restrictions for the Office Space Located at 120 Estudillo Avenue in the New Downtown Parking Garage (allows for the transfer of ownership of 262 Davis to the City and 120 Estudillo, the office space within the downtown garage, to the Chamber and the conditions under which the garage space will be shared)

WHEREAS, in 2008 the City of San Leandro Redevelopment Agency and the San Leandro Chamber of Commerce negotiated a lease, with an option to purchase, of the Chamber of Commerce property located at 262 Davis Street; and

WHEREAS, part of that agreement included the construction by the City of office space inside a new downtown parking garage that would be exchanged for the San Leandro Chamber of Commerce property at 262 Davis Street; and

WHEREAS, now before the City Council for review and approval are agreements substantially in the forms attached to effect the property exchange of the downtown parking garage office space from the City to the Chamber, and the transfer of 262 Davis Street from the Chamber to the City, as well as title to an office parcel within the new downtown parking garage with ingress / egress, parking, trash, communications, and HVAC amenities, and shared responsibility for certain aspects of upkeep through a reciprocal easement and a declaration of covenants, conditions, and restrictions for the use and upkeep of the garage office space.

NOW, THEREFORE, the City Council of the City of San Leandro does RESOLVE as

follows:

1. The Property Exchange and Indemnity Agreement with One and Only Right of First Offer is approved, and the City Manager is authorized to execute, subject to approval as to form by the City Attorney, the Property Exchange and Indemnity Agreement with One and Only Right of First Offer to the City for the City's office space located at 120 Estudillo Avenue in the new downtown parking garage in exchange for the Chamber of Commerce's property at 262 Davis Street; and

2. The Declaration of Reciprocal Easements and Covenants, Conditions, and Restrictions are approved, and the City Manager is authorized to execute, subject to approval as to form by the City Attorney, the reciprocal easements agreement and declaration of covenants, conditions, and restrictions for the office space located at 120 Estudillo Avenue.

**PROPERTY EXCHANGE AND INDEMNITY AGREEMENT
WITH ONE AND ONLY RIGHT OF FIRST OFFER**

THIS PROPERTY EXCHANGE AND INDEMNITY AGREEMENT WITH ONE AND ONLY RIGHT OF FIRST OFFER (this "Agreement"), dated as of _____, 2013 ("Effective Date"), is entered into by and between the City of San Leandro, a municipal corporation ("City") and the San Leandro Chamber of Commerce, a California nonprofit public benefit corporation ("Chamber"). City and Chamber are hereinafter collectively referred to as the "Parties."

RECITALS

A. Chamber is the owner of that certain real property located at 262 Davis Street in the City of San Leandro, known as Alameda County Assessor's Parcel No. 075-0001-009-02, and more particularly described in Exhibit A attached hereto (the "Chamber Property").

B. City is the owner of the real property located in the City of San Leandro at 120-122 Estudillo Avenue (the "City Property"). The City Property is improved with a four-story parking garage consisting of approximately 47,434 square feet (the "Garage") and approximately 2,175 square feet of commercial office space (the "Office"). City has, or shall, subdivide the City Property into two parcels as depicted on Parcel Map 10073 attached hereto as Exhibit B. As a result of such subdivision, the Office will constitute a parcel (the "Office Parcel" shown as Parcel 2 on the Parcel Map) and the Garage together with the land beneath the Garage and the Office will constitute a second parcel (the "Garage Parcel," shown as Parcel 1 on the Parcel Map).

C. The City Council has determined that the acquisition of the Chamber Property and the exchange of the Office Parcel for the Chamber Property pursuant to this Agreement will facilitate completion of the Town Hall Project, and will be in the best interests of the City and the health, safety and general welfare of the residents and taxpayers of the City.

NOW, THEREFORE, in consideration of the mutual covenants contained herein and other good and valuable consideration, the receipt and sufficiency of which are hereby acknowledged, the Parties agree as follows.

1. Recitals. The Parties acknowledge that the foregoing recitals are true and correct and are incorporated herein by this reference.

2. Chamber Conveyance to City. Chamber shall convey to City, and City shall accept from Chamber, the Chamber Property in accordance with the terms, covenants and conditions set forth herein. The conveyance of the Chamber Property from Chamber to City shall be accomplished by recordation of a grant deed, substantially in the form attached hereto as Exhibit C (the "Chamber Property Grant Deed").

3. Conveyance of Office Parcel. City shall convey to Chamber, and Chamber shall accept from City, the Office Parcel in accordance with the terms, covenants and conditions set forth herein. The conveyance of the Office Parcel from City to Chamber shall be accomplished by recordation of a grant deed, substantially in the form attached hereto as Exhibit D (the "**Office Parcel Grant Deed**").

4. Consideration. Chamber and City each agree that the fair market value of the Chamber Property is substantially equivalent to the fair market value of the Office Parcel, and that subject to the obligations of each Party expressly set forth in this Agreement, neither Party shall be obligated to pay further consideration to the other Party in connection with the conveyance of the Office Parcel and Chamber Property.

5. Escrow; Escrow Instructions. No later than five (5) business days following the Effective Date, the Parties shall open an escrow to consummate the exchange of property pursuant to this Agreement at the office of Old Republic Title Company located at 555 12th Street, Suite 2150, Oakland, California, 94607 ("**Title Company**" or "**Escrow Agent**") or such other title company as may be mutually agreed upon by the Parties. Upon the opening of escrow, the Parties shall deposit with the Escrow Agent an executed copy of this Agreement, which together with such additional instructions as may be executed by the Parties and delivered to the Escrow Agent, shall serve as the joint escrow instructions of Chamber and City for the property conveyances contemplated hereby.

6. Title Documents. No later than seven (7) days following the Effective Date, Chamber shall deliver or cause to be delivered to City an updated title report for the Chamber Property ("**Preliminary Report**") setting forth all liens, encumbrances, easements, restrictions, conditions, and other matters of record affecting Chamber's title to the Chamber Property ("**Title Exceptions**") together with copies of all instruments referred to therein, as requested by City. City shall approve or disapprove each Title Exception within seven (7) days following City's receipt of the Preliminary Report and documents relating to the Title Exceptions. Upon City's failure to object within such period, any Title Exceptions that are not disapproved shall be deemed to be Permitted Exceptions (as defined in Section 8).

If City objects to any Title Exception, Chamber shall use its best efforts at Chamber's sole expense to remove from title or otherwise satisfy each such exception no later than five (5) business days prior to the close of escrow and in a form that is reasonably satisfactory to City. If Chamber fails to remove or satisfy any Title Exception to the satisfaction of City, City shall have the option, in its sole discretion, to terminate this Agreement or to accept title subject to such exception. In the event City elects to terminate this Agreement, all funds and documents deposited into escrow by or on behalf of City shall be returned to City, and all rights and obligations of the Parties hereunder shall terminate.

7. Title Policy. It shall be a condition to the close of escrow that Title Company shall deliver to City, by not later than five (5) business days prior to the close of escrow, a title commitment for a CLTA Owner's Title Insurance Policy (or in City's election, an ALTA policy)

("Title Policy") to be issued by Title Company in an amount to be determined by City for the benefit and protection of City, showing title to the Chamber Property vested in City, subject only to the Permitted Exceptions, including such endorsements as may reasonably be requested by City and committing Title Company to issue the Title Policy to City upon the close of escrow.

8. Conveyance of Title. At the close of escrow, Chamber shall convey by grant deed to City fee simple title to the Chamber Property, free and clear of all recorded and unrecorded liens, encumbrances, restrictions, easements, and leases, except: (i) liens for nondelinquent general and special taxes, assessments and/or bonds; and (ii) such other conditions, liens, encumbrances, restrictions, easements and exceptions approved in writing by City or deemed approved by City as provided in Section 6 (all of the foregoing, are collectively hereinafter referred to as the "Permitted Exceptions").

9. Closing Documents.

(a) Chamber.

A. No later than three (3) business days prior to the Closing Date, Chamber shall deposit into escrow all of the following:

(i) The Chamber Property Grant Deed, duly executed and acknowledged;

(ii) If not previously delivered, a duly executed and acknowledged copy of that certain Reciprocal Easement Agreement and Declaration of Covenants pertaining to the Garage Parcel and the Office Parcel and to be executed by City and Chamber (the "REA");

(iii) A duly executed and acknowledged Declaration of the Right of First Offer described below in Section 25, substantially in the form attached hereto as Exhibit E (the "Declaration"); and

(iv) Such additional duly executed instruments and documents as the Escrow Agent may reasonably require to consummate the transactions contemplated hereby.

B. No less than one (1) business day prior to the close of escrow, Chamber shall deposit into escrow immediately available funds in the amount equal to the cost of any title policy that Chamber elects to purchase.

(b) City.

(A) No later than three (3) business days prior to the Closing Date, City shall deposit into escrow all of the following:

(i) A duly executed and acknowledged Certificate of Acceptance as required by Government Code Section 27281, substantially in the form attached to Exhibit C;

(ii) The Office Parcel Grant Deed, duly executed and acknowledged;

(iii) If not previously delivered, a duly executed and acknowledged copy of the REA;

(iv) A duly executed and acknowledged copy of the Declaration; and

(v) Such additional duly executed instruments and documents as the Escrow Agent may reasonably require to consummate the transactions contemplated hereby.

B. No less than one (1) business day prior to the close of escrow, City shall deposit into escrow immediately available funds in the amount equal to escrow fees, conveyance fees, transfer taxes and recording fees, the cost of any title policy that City elects to purchase, and the outstanding balance of any sum payable to Chamber pursuant to Section 13 below.

10. Close of Escrow. Unless this Agreement is terminated pursuant to the terms hereof or extended by mutual written consent of the Parties, escrow shall close no later than the date (“**Closing Date**”) which is _____ () days after the Effective Date. The Escrow Agent shall close escrow by: (A) recording each of the following in the Official Records of Alameda County: (i) the REA (if not previously recorded), (ii) the Chamber Property Grant Deed, (iii) the Office Parcel Grant Deed, and (iv) the Declaration; (B) issuing the Title Policy and delivering same to City; (C) issuing to Chamber any title policy Chamber has elected to acquire; (D) delivering to City conformed copies of each of the following indicating recording information thereon: (a) the REA, (b) Chamber Property Grant Deed, and (c) the Declaration; (E) delivering to Chamber conformed copies of each of the following indicating recording information thereon: (a) the REA, (b) Office Parcel Grant Deed, and (c) the Declaration. Possession of the Chamber Property shall be delivered to City at the close of escrow. Possession of the Office Parcel shall be delivered to Chamber at the close of escrow, provided however, the Chamber shall be permitted to occupy the Office Parcel prior to the close of escrow pursuant to Section 26 below.

11. Closing Costs. City shall pay the cost of City’s title policy, and all closing costs and escrow fees, recording fees, conveyance fees and transfer taxes (if any) applicable to the conveyance of the Chamber Property to City and the conveyance of the Office Parcel to Chamber. Chamber shall pay the cost of any title policy Chamber elects to acquire.

12. Prorations. At the close of escrow, the Escrow Agent shall make the following prorations: (i) property taxes shall be prorated as of the close of escrow based upon the most recent tax bill available, including any property taxes which may be assessed after the close of escrow but which pertain to the period prior to the transfer of title to the Property to City, regardless of when or to whom notice thereof is delivered; and (ii) any bond or assessment that

constitutes a lien on the Property at the close of escrow shall be assumed by City. Rents payable under any land leases and any utility and sewer service charges shall be prorated as of the close of escrow.

13. Relocation. At close of escrow, City will pay to Chamber the sum of Ten Thousand Dollars (\$10,000) to cover Chamber's costs incurred in moving to the Office Parcel. Chamber hereby agrees that the foregoing payment shall satisfy all obligations (if any) that City may have pursuant to the California Uniform Relocation Act, Government Code Section 7260, *et seq.* (the "**Relocation Act**") and hereby knowingly and willingly waives all rights Chamber may have to claim any additional benefits pursuant to the Relocation Act. Chamber further acknowledges and agrees that it has carefully read the contents of the waiver and release set forth in this Section and that, in executing this Agreement, it does so with full knowledge of any right which it may have, that it has received independent legal advice from its attorneys, or in the alternative, knowingly has determined not to seek legal advice with respect to the matter set forth herein. Chamber hereby voluntarily and knowingly waives, releases and discharges forever City from any claims for any such benefits.

14. Release. Chamber is aware of and familiar with the provisions of Section 1542 of the California Civil Code which provides:

A GENERAL RELEASE DOES NOT EXTEND TO CLAIMS WHICH THE CREDITOR DOES NOT KNOW OR SUSPECT TO EXIST IN HIS FAVOR AT THE TIME OF EXECUTING THE RELEASE, WHICH IF KNOWN BY HIM MUST HAVE MATERIALLY AFFECTED HIS SETTLEMENT WITH THE DEBTOR.

As such relates to Section 13 of this Agreement, Chamber hereby waives and relinquishes all rights and benefits which it may have under Section 1542 of the California Civil Code. This Section 14 shall survive the close of escrow and the expiration or earlier termination of this Agreement.

Chamber Initials

15. City's Conditions to Closing. The close of escrow and City's obligation to purchase the Chamber Property are conditioned upon: (i) the performance by Chamber of each obligation to be performed by Chamber under this Agreement within the applicable time period, or the waiver by City of such obligation; (ii) Chamber's representations and warranties contained in this Agreement being true and correct as of the date hereof and the close of escrow; (iii) the commitment by Title Company to issue and deliver the Title Policy, subject only to the Permitted Exceptions; and (iv) City's approval of the condition of the Chamber Property pursuant to Section 16.

Should any condition to closing fail to occur, excepting any such conditions that have been waived by City, City shall have the right, exercisable by giving written notice to Chamber, to cancel the escrow, terminate this Agreement, and recover any and all amounts paid by City to

Chamber or deposited with the Escrow Agent by or on behalf of City. The exercise of this right by City shall not constitute a waiver by City of any other rights City may have at law or in equity.

16. Due Diligence; AS-IS Purchase. Each Party represents and warrants that it has had an opportunity prior to the Effective Date to examine, inspect and conduct tests of the property to be conveyed to such Party pursuant to this Agreement. During the period (“**Due Diligence Period**”) commencing upon the Effective Date and ending at 5:00 p.m. on the seventh (7th) day following the Effective Date (“**Due Diligence Period Termination**”), City shall have the right to perform due diligence regarding the investigation, assessment, and monitoring of the environmental condition of the Chamber Property, and unless City elects to terminate this Agreement pursuant to the terms hereof, City will purchase the Chamber Property in its “**AS IS**” condition as such condition exists at the Due Diligence Period Termination, subject only to the representations, warranties and covenants of Chamber described in Section 20 and 21.

During the Due Diligence Period, Chamber shall have the right to perform due diligence regarding the investigation, assessment, and monitoring of the environmental condition of the Office Parcel, and unless Chamber elects to terminate this Agreement pursuant to the terms hereof, Chamber will purchase the Office Parcel in its “**AS IS**” condition as such condition exists at the Due Diligence Period Termination, subject only to the representations, warranties and covenants of City described in Section 22.

Should City fail to approve the condition of the Chamber Property or its feasibility for City’s intended use within two (2) business days following the Due Diligence Period Termination, City shall have the right, exercisable by giving written notice to Chamber, to cancel the escrow, terminate this Agreement, and recover any and all amounts paid by City to Chamber or deposited with the Escrow Agent by or on behalf of City. The exercise of this right by City shall not constitute a waiver by City of any other rights City may have at law or in equity. If City fails to deliver notice of its election to terminate the Agreement by the Due Diligence Termination date, City shall be deemed to have conclusively approved the condition of the Chamber Property and to have agreed to accept the Chamber Property on the Closing Date in its condition as of the Due Diligence Period Termination, subject to Sections 21, 23 and 24 below.

Should Chamber fail to approve the condition of the Office Parcel or its feasibility for Chamber’s intended use within two (2) business days following the Due Diligence Period Termination, Chamber shall have the right, exercisable by giving written notice to City, to cancel the escrow, terminate this Agreement, and recover any and all amounts paid by Chamber to City or deposited with the Escrow Agent by or on behalf of Chamber. The exercise of this right by Chamber shall not constitute a waiver by Chamber of any other rights Chamber may have at law or in equity. If Chamber fails to deliver notice of its election to terminate the Agreement by the Due Diligence Termination date, Chamber shall be deemed to have conclusively approved the condition of the Office Parcel and to have agreed to accept the Office Parcel on the Closing Date in its condition as of the Due Diligence Period Termination, subject to Sections 22, 23 and 24 below.

17. Studies, Reports and Investigations. Each Party agrees to make available to the other Party within two (2) business days following the Effective Date, any and all information, studies,

reports, investigations, contracts, leases, rental agreements and other obligations concerning or relating to its respective property that is within such Party's possession or reasonably available to such Party, including without limitation surveys, studies, reports and investigations concerning the property's physical, environmental or geological condition, habitability, or the presence or absence of Hazardous Materials in, on or under the property and its compliance with Environmental Laws (as defined in Section 20).

18. Intentionally omitted.

19. Chamber's Conditions to Closing. The close of escrow and Chamber's obligation to sell the Chamber Property pursuant to this Agreement are conditioned upon: (i) the performance by City of each obligation to be performed by City under this Agreement within the applicable time period, or waiver by Chamber of such obligation; and (ii) City's representations and warranties contained in this Agreement being true and correct as of the date hereof and the close of escrow.

20. Chamber's Representations and Warranties. Chamber hereby represents and warrants that to Chamber's actual knowledge, except as disclosed in writing to City, as of the date hereof and as of the close of escrow:

(a) Except for any Permitted Exceptions and any agreements that have been disclosed to City in writing, there are no leases, licenses, contracts or other agreements relating to the Chamber Property which will be in force after the Closing Date.

(b) There is no pending (nor has Chamber received notice of any threatened) action, litigation, condemnation or other proceeding against the Chamber Property or against Chamber with respect to the Chamber Property.

(c) Chamber has received no notice from any governmental authority having jurisdiction over the Chamber Property to the effect that the Chamber Property is not in compliance with applicable laws and ordinances (including any laws concerning the use, generation, handling, disposal or storage of Hazardous Materials (as defined below)).

(d) Chamber has not received any notice from any insurer of defects or conditions relating to the Chamber Property that must be corrected.

(e) There has been no release of any Hazardous Material (as defined below) at, under or upon the Chamber Property, in an amount which would, as of the date hereof, give rise to an Environmental Compliance Cost (as defined below). The term "**Hazardous Material**" shall mean asbestos, petroleum products, and any other hazardous waste or substance which has, as of the date hereof, been determined to be hazardous or a pollutant by the U.S. Environmental Protection Agency, the U.S. Department of Transportation, or any State or Federal instrumentality authorized to regulate substances in the environment which has jurisdiction over the Chamber Property (each being referred to herein as an "**Environmental Agency**") which substance causes the Chamber Property (or any part thereof) to be in material violation of any

applicable Environmental Law, and shall include, but not be limited to: (A) a "hazardous substance" pursuant to Section 101 of the Comprehensive Environmental Response, Compensation and Liability Act, 42 U.S.C. §9601(14), Section 311 of the Federal Water Pollution Control Act, 33 U.S.C. §1321; (B) a "hazardous waste" pursuant to Section 1004 or Section 3001 of the Resource Conservation and Recovery Act, 42 U.S.C. §§6903, 6921; (C) a toxic pollutant under Section 307(a)(1) of the Federal Water Pollution Control Act, 33 U.S.C. §1317(a)(1); (D) a "hazardous air pollutant" under Section 112 of the Clean Air Act, 42 U.S.C. §7412; (E) a "hazardous material" under the Hazardous Materials Transportation Uniform Safety Act of 1990, 49 U.S.C. App. §1802(4); (F) a "hazardous material" pursuant to the California Health & Safety Code; or (G) toxic or hazardous pursuant to regulations promulgated under the aforementioned laws (all of the foregoing laws, rules and regulations as any may be amended from time to time being collectively referred to herein as "**Environmental Laws**"); provided, however, that the term "**Hazardous Material**" shall not include motor oil and gasoline contained in or discharged from vehicles not used primarily for the transport of motor oil or gasoline, or materials which are stored, used, held, or disposed of in compliance with all applicable Environmental Laws. The term "**Environmental Compliance Cost**" means any out-of-pocket cost, fee or expense reasonably incurred directly to satisfy any requirement imposed by an Environmental Agency to bring the Chamber Property into compliance with applicable Environmental Laws directly relating to the existence on the Chamber Property of any Hazardous Material.

Chamber further represents and warrants that this Agreement and all other documents delivered or to be delivered in connection herewith prior to or at the close of escrow shall at the time of their delivery: (a) have been duly authorized, executed, and delivered by Chamber; (b) be the binding obligations of Chamber; (c) collectively be sufficient to transfer all of Chamber's right, title and interest in and to the Chamber Property; and (d) not be in violation of the provisions of any agreement to which Chamber is a party or which affects the Chamber Property. Chamber further represents and warrants that the persons who have executed this Agreement on behalf of Chamber are authorized to do so, that Chamber has the legal right to enter into this Agreement and to perform all of its terms and conditions, and that this Agreement is enforceable against Chamber in accordance with its terms.

Chamber shall notify City of any facts that would cause any of the representations contained in this Agreement to be untrue as of the close of escrow. If City reasonably believes that any such fact materially and adversely affects the Chamber Property, City shall have the option to terminate this Agreement by delivering written notice thereof to Chamber. In the event City elects to terminate this Agreement, all funds and documents deposited into escrow by or on behalf of City shall be returned to City, and all rights and obligations hereunder shall terminate.

21. Chamber's Covenants. Chamber covenants that from the date of this Agreement and through the close of escrow, Chamber: (i) shall not permit any liens, encumbrances, or easements to be placed on the Chamber Property other than Permitted Exceptions; (ii) shall not without the prior written consent of City, enter into any agreement regarding the sale, rental, management, repair, improvement, or any other matter affecting the Chamber Property that would be binding on City or the Chamber Property after the close of escrow; (iii) shall not permit any act of waste

or act that would tend to diminish the value of the Chamber Property for any reason, except that caused by ordinary wear and tear; and (iv) shall maintain the Chamber Property in its condition as of the date hereof, ordinary wear and tear excepted, and shall manage the Chamber Property substantially in accordance with Chamber's established practices.

22. City Representations, Warranties and Covenants. City represents, warrants and covenants that this Agreement and all other documents delivered in connection herewith, prior to or at the close of escrow shall at the time of their delivery: (i) be duly authorized, executed, and delivered by City; (ii) be the binding obligations of City; and (iii) not be in violation of the provisions of any agreement to which City is a party. City further represents and warrants that the persons who have executed this Agreement on behalf of City are duly authorized to do so, that City has the legal right to enter into this Agreement and to perform all of its terms and conditions, and that Agreement is enforceable against City in accordance with its terms.

City further represents and warrants as follows:

(a) Except for any Permitted Exceptions and any agreements that have been disclosed to Chamber in writing, there are no leases, licenses, contracts or other agreements relating to the Office Parcel which will be in force after the Closing Date.

(b) There is no pending (nor has City received notice of any threatened) action, litigation, condemnation or other proceeding against the Office Parcel or against City with respect to the Office Parcel.

(c) City has received no notice from any governmental authority having jurisdiction over the Office Parcel to the effect that the Office Parcel is not in compliance with applicable laws and ordinances (including any laws concerning the use, generation, handling, disposal or storage of Hazardous Materials (as defined above)).

(d) City has not received any notice from any insurer of defects or conditions relating to the Office Parcel that must be corrected.

23. Damage and Destruction. In the event of any damage or other loss to the Chamber Property, or any portion thereof, caused by fire, flood or other casualty prior to the close of escrow in an amount not exceeding \$50,000, City shall not be entitled to terminate this Agreement, but shall be obligated to close the escrow and purchase the Chamber Property as provided in this Agreement, without abatement in the Purchase Price, provided that Chamber shall: (i) assign and transfer to City all of Chamber's rights under any insurance policy covering the damage or loss, and all claims for monies payable from Chamber's insurer(s) in connection with the damage or loss, and (ii) pay to City at the close of escrow the amount of Chamber's deductible under the insurance policy or policies covering the damage or loss. In the event of damage or destruction of the Chamber Property or any portion thereof prior to the close of escrow in an amount in excess of \$50,000, City may elect either to terminate this Agreement upon written notice to Chamber, or to consummate the purchase of the Chamber Property, in which case Chamber shall (i) assign and transfer to City all of Chamber's rights under any

insurance policy covering the damage or loss, and all claims for monies payable from Chamber's insurer(s) in connection with the damage or loss, and (ii) pay to City at the close of escrow the amount of Chamber's deductible under the insurance policy or policies covering the damage or loss. If City elects to terminate this Agreement, all funds and documents deposited into escrow by or on behalf of City shall be returned to City, and all rights and obligations of the Parties hereunder shall terminate.

In the event of any damage or other loss to the Office Parcel, or any portion thereof, caused by fire, flood or other casualty prior to the close of escrow in an amount not exceeding \$50,000, Chamber shall not be entitled to terminate this Agreement, but shall be obligated to close the escrow and purchase the Office Parcel as provided in this Agreement, without abatement in the Purchase Price, provided that City shall: (i) assign and transfer to Chamber all of City's rights under any insurance policy covering the damage or loss, and all claims for monies payable from City's insurer(s) in connection with the damage or loss, and (ii) pay to Chamber at the close of escrow the amount of City's deductible under the insurance policy or policies covering the damage or loss. In the event of damage or destruction of the Office Parcel or any portion thereof prior to the close of escrow in an amount in excess of \$50,000, Chamber may elect either to terminate this Agreement upon written notice to City, or to consummate the purchase of the Office Parcel, in which case City shall (i) assign and transfer to Chamber all of City's rights under any insurance policy covering the damage or loss, and all claims for monies payable from City's insurer(s) in connection with the damage or loss, and (ii) pay to Chamber at the close of escrow the amount of City's deductible under the insurance policy or policies covering the damage or loss. If Chamber elects to terminate this Agreement, all funds and documents deposited into escrow by or on behalf of Chamber shall be returned to Chamber, and all rights and obligations of the Parties hereunder shall terminate.

24. Condemnation. If prior to Close of Escrow, a material portion of the Chamber Property is taken by eminent domain (or an action of eminent domain has been commenced against all or any portion of the Chamber Property) (excluding for purposes of this Section, the exercise of any eminent domain powers by the City), upon Chamber's receipt of notice thereof Chamber shall promptly notify City of such fact, and City shall have the option to terminate this Agreement upon notice to Chamber given not later than ten (10) days after City's receipt of Chamber's notice. If City elects to terminate this Agreement, all funds and documents deposited into escrow by or on behalf of City shall be returned to City, and all rights and obligations of the Parties hereunder shall terminate.

If City does not exercise such option to terminate this Agreement, Chamber shall assign to City at the close of escrow, and City shall be entitled to negotiate for, receive, and keep, all awards, and rights to receive future awards, for such taking by eminent domain, and the transaction contemplated by this Agreement shall be consummated pursuant to the terms hereof, without any reduction in value of the consideration for the Property.

25. One and Only Right of First Offer. Chamber hereby grants to City a One and Only Right of First Offer to purchase the Office Parcel in the event that at any time after Chamber's acquisition thereof, Chamber determines to sell, lease or otherwise convey the Office

Parcel. This grant of a One and Only Right of First Offer to City means that Chamber will not solicit offers for, nor accept an offer for the sale, lease or other conveyance of the Office Parcel without first offering to sell or lease such property to City, once and only once, by written notice ("Notice of Offer"). If City and Chamber do not reach agreement on the terms for the sale of the Office Parcel within forty five (45) days following Chamber's delivery of a Notice of Offer to City, then Chamber shall be free to solicit and accept offers from other parties; provided however, Chamber shall not accept an offer, nor agree to sell the Office Parcel on terms equal to or less favorable to Chamber than the terms set forth in City's last offer for such property, without first offering such property to City on the same terms. City's One and Only Right of First Offer shall begin on the Effective Date, and shall continue throughout the period of time that Chamber owns the Office Parcel. The provisions of this Section 25 shall survive the close of escrow, and shall be memorialized in a Declaration of One and Only Right of First Offer substantially in the form attached hereto as Exhibit E, which shall be executed by the Parties and recorded in the Official Records of Alameda County.

26. Occupancy Prior to Close of Escrow; Indemnity. City hereby grants to Chamber a revocable license to occupy the Office Parcel prior to close of escrow subject to the terms and conditions set forth in this Section 26.

Chamber's use and occupancy of the Office Parcel shall be subject to all of the conditions set forth in the following paragraphs (a) through (j):

(a) If escrow for the sale of the Office Parcel to Chamber does not occur by _____, 20__ : (i) Chamber shall vacate the Office Parcel and remove all personal property and equipment from the Office Parcel by not later than _____, 20__ ("License Termination Date"); (ii) if Chamber remains in occupancy of the Office Parcel past the License Termination Date, Chamber shall pay to City One Hundred and Fifty Dollars (\$150) for each day following the License Termination Date that Chamber occupies the Office Parcel, and (iii) City shall have the right to eject Chamber from the Office Parcel if Chamber fails to vacate the Office Parcel upon ten (10) days' written notice.

(b) Chamber shall pay all costs and expenses related to Chamber's use of the Office Parcel which accrue during or are attributable to any period during which Chamber remains in occupancy of the Office Parcel. Such costs and expenses shall include, without limitation, all costs and expenses attributable to, paid, or incurred in connection with the operation, repair, and maintenance of the improvements, all water, sewer and utility charges, insurance premiums, and all charges for refuse disposal, janitorial, landscape maintenance and other services provided to the Office Parcel.

(c) Chamber shall pay, prior to delinquency, all real property taxes, possessory interest taxes, license and permit fees, sales, use or occupancy taxes, and general and special assessments pertaining to the Office Parcel which accrue during or are attributable to any period during which Chamber occupies the Office Parcel.

(d) Chamber shall occupy the Office Parcel in its as-is condition as of the commencement of the license period. Chamber acknowledges that City shall have no responsibility for the repair or maintenance of the Office Parcel, and Chamber releases City from all Claims (defined below) related in whole or in part, directly or indirectly, to the condition of the Office Parcel.

(e) Chamber shall not use or permit Hazardous Materials to be used in, on or under the Office Parcel except for substances used in the ordinary course of Chamber's business and used and disposed of in compliance with all applicable state, federal and local laws, rules and regulations.

(f) Chamber shall comply with all state, federal and local laws, rules and regulations in connection with its use and occupancy of the Office Parcel.

(g) Chamber shall indemnify, defend (with counsel approved by City) and hold harmless, City and its elected and appointed officers, officials, employees, agents, consultants, and contractors from and against all claims, liabilities, losses, damages, fines, penalties, claims, demands, suits, actions, causes of action, judgments, costs and expenses (including without limitation reasonable attorneys' fees and court costs) (collectively "Claims") including without limitation, Claims relating to property damage or personal injury, arising from Chamber's use and occupancy of the Office Parcel, including without limitation, any such Claims arising from the gross negligence of Chamber or its officers, agents, contractors, employees or invitees, except to the extent any such Claim arises from City's gross negligence or willful misconduct. The provisions of this paragraph shall survive the close of escrow and the termination of this Agreement.

(h) Throughout the period during which Chamber remains in occupancy of the Office Parcel, Chamber shall maintain, at Chamber's expense: (i) Comprehensive General Liability insurance issued by a carrier authorized to sell insurance in the State of California, written on an occurrence basis, and providing coverage for bodily injury, death and property damage caused by or occurring in connection with Chamber's use and occupancy of the Office Parcel with a policy limit of at least \$3,000,000 per occurrence, \$5,000,000 in the aggregate, with commercially reasonable deductibles, insuring the Chamber (as named insured) and the City (as additional insured) against all claims, demands, actions, suits, or personal injury or property damage occurring upon, in, or about the Office Parcel, or arising from any acts or omissions of Chamber or any of its agents or employees. The commercial General Liability policy shall insure for contractual indemnity and contain a cross-liability endorsement. (ii) Worker's Compensation insurance in compliance with the requirements of law, and (iii) "all risks" property insurance (or its equivalent) covering all improvements located in the Office Parcel in a minimum amount equal to 100% of the reasonable replacement cost thereof. The property insurance policy shall contain a severability of interests clause.

All insurance coverages required to be carried under this section shall be carried with insurance companies that are (i) licensed to do business in California and (ii) rated in the

most current Best's Insurance Guide as having a general policy holder rating of A or better and a financial rating of "VII" or better. All insurance policies required to be carried by Chamber shall be effected under standard form policies. Such insurance shall provide that the same may not be canceled without thirty (30) days prior written notice. Chamber shall provide to City certificated evidencing the fact that such insurance has been obtained. Additionally, upon the request of City, Chamber shall increase the limits of insurance carried by it hereunder, and shall carry types of insurance in addition to those required hereunder, to the extent such additional types of coverage first become standard at comparable properties after the date hereof.

Chamber and City hereby waives, and releases the other from any and all claims, liabilities, and rights of action with respect to any property loss caused by the other that is covered by the property insurance maintained by the other. Chamber and City agrees that any property insurance maintained by it shall contain a waiver by the insurer of any and all right of subrogation against the other.

27. Miscellaneous.

27.1 Notices. Except as otherwise specified in this Agreement, all notices to be sent pursuant to this Agreement shall be made in writing, and sent to the Parties at their respective addresses specified below or to such other address as a Party may designate by written notice delivered to the other parties in accordance with this Section. All such notices shall be sent by: personal delivery, in which case notice is effective upon delivery; (ii) certified or registered mail, return receipt requested, in which case notice shall be deemed delivered on receipt if delivery is confirmed by a return receipt; (iii) nationally recognized overnight courier, with charges prepaid or charged to the sender's account, in which case notice is effective on delivery if delivery is confirmed by the delivery service; or (iv) facsimile transmission, in which case notice shall be deemed delivered upon transmittal, provided that (a) a duplicate copy of the notice is promptly delivered by first-class or certified mail or by overnight delivery, or (b) a transmission report is generated reflecting the accurate transmission thereof. Any notice given by facsimile shall be considered to have been received on the next business day if it is received after 5:00 p.m. recipient's time or on a nonbusiness day.

Chamber:

San Leandro Chamber of Commerce
120 Estudillo Avenue
San Leandro, CA 94577
Attn: Chief Executive Officer

City:

City of San Leandro
835 East 14th Street
San Leandro, CA 94577
Attn: City Engineer

27.2 No Brokers. Each Party hereby represents and warrants to the other Party that it has retained no broker or other party to whom a commission or finder's fee is due with respect to the transactions contemplated hereby. Each Party shall defend, indemnify and hold the other Party harmless from and against all claims, expenses, costs, or arising in connection with a breach of this warranty and representation. The terms of this Section shall survive the expiration or earlier termination of this Agreement.

27.3 Attorneys' Fees. If either Party fails to perform any of its obligations under this Agreement, or if any dispute arises between the Parties concerning the meaning or interpretation of any provision hereof, then the prevailing party in any proceeding in connection with such dispute shall be entitled to the costs and expenses it incurs on account thereof and in enforcing or establishing its rights hereunder, including, without limitation, court costs and reasonable attorneys' fees and disbursements.

27.4 Entire Agreement. This Agreement, together with Exhibits A through E, attached hereto and incorporated herein by reference, constitutes the entire agreement of the Parties with respect to the subject matter hereof and supersedes all prior negotiations and agreements with respect thereto.

27.5 No Merger. The obligations stated herein that are intended to operate after the Closing Date shall not merge with the transfer of title to the Property but shall remain in effect until fulfilled as provided herein.

27.6 Governing Law. This Agreement shall be governed by and construed in accordance with the laws of the State of California without regard to principles of conflicts of laws.

27.7 Interpretation; Captions. The section headings used herein are solely for convenience and shall not be used to interpret this Agreement. The Parties acknowledge that this Agreement is the product of negotiation and compromise on the part of both Parties, and the Parties agree, that since both Parties have participated in the negotiation and drafting of this Agreement, this Agreement shall not be construed as if prepared by one of the Parties, but rather according to its fair meaning as a whole, as if both Parties had prepared it.

27.8 No Third Party Beneficiaries. Nothing contained in this Agreement is intended by the Parties, nor shall any provision of this Agreement be deemed or construed by the Parties or by any third person, to be for the benefit of any third party, nor shall any third party have any right to enforce any provision of this Agreement or be entitled to damages for any breach by Chamber or City of any of the provisions of this Agreement.

27.9 Amendments. This Agreement may be modified or amended only by an instrument in writing executed by both Chamber and City.

27.10 Assignment Prohibited. This Agreement and the rights conferred hereunder may not be assigned by operation of law or otherwise absent the express written consent of the Parties.

27.11 Escrow Cancellation Charges. If the escrow fails to close by reason of a default by Chamber or City hereunder, such defaulting party shall pay all escrow or other Title Company charges. If the escrow fails to close for any reason other than default by Chamber or City, then Chamber and City shall each pay one-half of such charges.

27.12 Counterparts. This Agreement may be executed in multiple counterparts, each of which shall be an original, and all of which taken together shall constitute one agreement.

27.13 Further Assurances. City and Chamber each agree to undertake such other actions as may reasonably be necessary to carry out the intent of this Agreement, including without limitation, the execution of any additional documents which may be required to effectuate the transactions contemplated hereby.

27.14 Severability. If any term, provision, or condition of this Agreement is held by a court of competent jurisdiction to be invalid or unenforceable, the remainder of this Agreement shall continue in full force and effect unless the rights and obligations of the Parties have been materially altered or abridged thereby

27.15 Non-Liability of Officials, Employees and Agents. No member, official, employee or agent of City shall be personally liable in the event of any default or breach hereunder by either Party.

IN WITNESS WHEREOF, the Parties have executed this Agreement as of the date first written above.

CITY OF SAN LEANDRO,
a municipal corporation

By: _____

Its: _____

Attest: _____

APPROVED AS TO FORM:

City Attorney

SAN LEANDRO CHAMBER OF COMMERCE,
a California nonprofit public benefit corporation

By:  _____

Its: President & CEO

By:  _____

Its: Chair, Board of Directors

Exhibit A

CHAMBER PROPERTY

Portion of Lots "H", "I", and "J", Block 1, Map of the Town of San Leandro, filed February 27, 1855, Map Book 1, page 19, Alameda County Records, bounded as follows:

Beginning at a point on the northwestern line of Davis Street, distant thereon North $62^{\circ} 00'$ east 33 feet from the northeastern line of Hays Street, as said streets are shown on the said map, said point of beginning being distant north $62^{\circ} 00'$ east 40.10 feet, more or less, along said line of Davis Street from the northeastern line of Hays Street, as now improved; and running thence along said line of Davis Street north $62^{\circ} 00'$ east 52 feet; thence north $28^{\circ} 00'$ west 197.92 feet; thence along the southeastern line of the parcel of land described in the deed to City of San Leandro, recorded September 5, 1957 in Book 8460 of Official Records of Alameda County, page 321, said line being the southeastern line of Hays Street, as now improved, south $42^{\circ} 00'$ west 31.84 feet and southwesterly, on the arc of a tangent curve to the left, with a radius of 94.50 feet, a distance of 24.98 feet to a line drawn north $28^{\circ} 00'$ west from the point of beginning; thence south $28^{\circ} 00'$ east 175.71 feet to the point of beginning.

Assessor's Parcel Number: 075-0001-009-02

Exhibit B

OFFICE PARCEL
(Attached PDF of Parcel Map 10073)

PARCEL MAP 10073

BEING A SUBDIVISION OF THOSE PARCELS OF LAND DESCRIBED IN THAT CERTAIN GRANT DEED BEING A SUBDIVISION OF THOSE PARCELS OF LAND DESCRIBED IN THAT CERTAIN GRANT DEED DATED AND RECORDED IN THE PUBLIC RECORDS OF ALAMEDA COUNTY, CALIFORNIA, RECORDED UNDER INSTRUMENT NUMBER 97152847, ALL OFFICIAL RECORDS OF ALAMEDA COUNTY.

CITY OF SAN LEANDRO - ALAMEDA COUNTY - CALIFORNIA
JANUARY 2013

KIER & WRIGHT
CIVIL ENGINEERS & SURVEYORS, INC.
11000 UNIVERSITY AVENUE, SUITE 100
LIVERMORE, CALIFORNIA 94551
PHONE (925) 245-8776
FAX (925) 245-8798

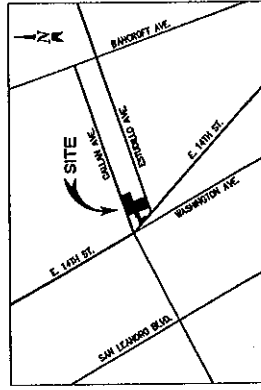

VICINITY MAP
NOT TO SCALE

OWNER'S STATEMENT:

I, THE UNDERSIGNED HEREBY STATE THAT I AM THE OWNER OF THE LAND DELINEATED AND DIMENSIONED WITHIN THE EXTERIOR BOUNDARY LINES ON THE HEREBY ENCLOSED MAP ENTITLED "PARCEL MAP NO. 10073," THAT SAID OWNER CONSENTS TO THE PREPARATION AND FILING OF THIS MAP.

THIS MAP SHOWS ALL THE EASEMENTS ON THE PROMISES, OR OF RECORD, THE CITY OF SAN LEANDRO, A MUNICIPAL CORPORATION

BY: _____ DATE: _____
ITS: _____

OWNER'S ACKNOWLEDGMENT:

STATE OF CALIFORNIA)
COUNTY OF _____)
ON _____ 20____ BEFORE ME
(HERE INSERT NAME AND TITLE OF THE OFFICER)

PERSONALLY APPEARED _____ WHO PROVED TO ME ON THE BASIS OF SATISFACTORY EVIDENCE TO BE THE PERSON(S) WHOSE NAME(S) IS/ARE SHOWN IN THE INSTRUMENT AUTHORIZED TO SIGN SAID INSTRUMENT, AND THAT SAID PERSON(S) EXECUTED THE INSTRUMENT OF RECORD, AND THAT SAID PERSON(S) ARE THE PERSON(S) ACTUALLY DESIGNATED IN THE INSTRUMENT.

I CORRECTLY UNDERSTAND THE NATURE AND CONTENTS OF THE INSTRUMENT OF RECORD, AND THAT THE INSTRUMENT OF RECORD IS TRUE AND CORRECT.

WITNESS MY HAND,

SIGNATURE _____
PRINTED NAME _____
COMMISSION NUMBER _____
COMMISSION EXPIRES _____
PRINCIPAL PLACE OF BUSINESS _____ COUNTY _____

SURVEYOR'S STATEMENT:

THIS MAP WAS PREPARED BY ME OR UNDER MY DIRECTION AND IS BASED UPON A FIELD SURVEY IN CONFORMANCE WITH THE REQUIREMENTS OF THE SURVEYOR'S MAP ACT AND LOCAL ORDINANCE AT THE REQUEST OF THE CITY OF SAN LEANDRO IN OCTOBER 2011. I HEREBY STATE THAT I AM A LICENSED SURVEYOR IN THE STATE OF CALIFORNIA AND THAT I AM A LICENSED SURVEYOR IN THE COUNTY OF SAN LEANDRO. I HEREBY STATE THAT THE INFORMATION CONTAINED ON THIS MAP IS TRUE AND CORRECT TO THE BEST OF MY KNOWLEDGE AND BELIEF AND THAT I AM NOT PROVIDING ANY GUARANTEE AS TO THE ACCURACY OF THE INFORMATION SHOWN AND OCCUPY BE POSITIONS INDICATED AND ARE SUBJECT TO CHANGE THE SURVEY TO BE RETRACTED.

DATE _____

KEITH WOODS, P.L.S., 7253
LICENSE EXPIRES 12-31-2013



CITY SURVEYOR'S STATEMENT:

I, FRANK C. BELLEZ, CITY SURVEYOR FOR THE CITY OF SAN LEANDRO, DO HEREBY STATE THAT I HAVE EXAMINED THE HEREBY ENCLOSED PARCEL MAP ENTITLED "PARCEL MAP NO. 10073," CONSISTING OF THREE (3) SHEETS, AND THAT THE SURVEY DATA SHOWN UPON SAID MAP IS TECHNICALLY CORRECT.

DATE _____
FRANK C. BELLEZ, L.S., No. 2590
CITY SURVEYOR FOR THE CITY OF SAN LEANDRO,
ALAMEDA COUNTY, CALIFORNIA

CITY ENGINEER'S STATEMENT:

I, WENDY JOSEPH, CITY ENGINEER OF THE CITY OF SAN LEANDRO, COUNTY OF ALAMEDA, STATE OF CALIFORNIA, DO HEREBY STATE AS FOLLOWS:

- 1) THAT I HAVE EXAMINED THE HEREBY ENCLOSED PARCEL MAP ENTITLED "PARCEL MAP NO. 10073," CONSISTING OF THREE (3) SHEETS, THE STATEMENT BEING ON SHEET ONE (1) THEREOF.
- 2) THE SUBDIVISION AS SHOWN UPON SAID PARCEL MAP IS SUBSTANTIALLY THE SAME AS SAID SUBDIVISION APPEARED ON THE TENTATIVE MAP, IF REQUIRED, AND ANY APPROVED ALTERNATION THEREOF.
- 3) ALL PROVISIONS OF THE SUBDIVISION MAP ACT AS THE STATE OF CALIFORNIA AND ALTERNATIVE MAPS, IF REQUIRED, HAVE BEEN COMPLIED WITH.

IN WITNESS WHEREOF, I HAVE HERETO SET MY HAND THIS _____ DAY OF _____ 20____

DATE _____
WENDY JOSEPH, P.E., No. 00570
CITY ENGINEER FOR THE CITY OF SAN LEANDRO,
ALAMEDA COUNTY, CALIFORNIA

CERTIFICATE OF CLERK OF BOARD OF SUPERVISORS:

QUESTA ORDINE, ASSISTANT CLERK OF THE BOARD OF SUPERVISORS FOR THE COUNTY OF ALAMEDA, STATE OF CALIFORNIA, DO HEREBY CERTIFY, AS DECEDED BELOW THAT:
 AN APPROVED BOND HAS BEEN FILED WITH THE SUPERVISORS OF THE SAID COUNTY AND SAID IN THE AMOUNT OF \$ _____ CONDITIONED FOR PAYMENT OF ALL TAXES AND SPECIAL ASSESSMENTS COLLECTED AS TAXES WHICH ARE NOW A LIEN AGAINST SAID LAND OF ANY PART THEREOF BUT NOT YET PAYABLE AND WAS ONLY APPROVED BY SAID BOARD IN SAID AMOUNT.

ALL TAXES AND SPECIAL ASSESSMENTS COLLECTED AS TAXES HAVE BEEN PAID AS CERTIFIED BY THE TREASURER/TAX COLLECTOR OF THE COUNTY OF ALAMEDA.

QUESTA ORDINE, ASSISTANT CLERK OF THE BOARD OF SUPERVISORS FOR THE COUNTY OF ALAMEDA, STATE OF CALIFORNIA,
DATE: _____

BY: _____
DEPUTY CLERK

CITY CLERK'S STATEMENT:

I, MARGARITA HANCO, CITY CLERK AND CLERK OF THE COUNCIL OF THE CITY OF SAN LEANDRO, COUNTY OF ALAMEDA, STATE OF CALIFORNIA, DO HEREBY STATE THAT THE HEREBY ENCLOSED PARCEL MAP NO. 10073, CONSISTING OF THREE (3) SHEETS, THIS STATEMENT BEING ON SHEET 1 THEREOF, WAS PRESENTED TO SAID COUNCIL OF THE CITY OF SAN LEANDRO AS PROVIDED BY LAW AT A REGULAR MEETING HELD ON THE _____ DAY OF _____ 20____ AND THAT SAID COUNCIL OF THE CITY OF SAN LEANDRO DO THESE UPON BY RESOLUTION NUMBER _____ DULY PASSED AND ADOPTED AT SAID MEETING, APPROVE SAID MAP.

IN WITNESS WHEREOF, I HAVE HERETO SET MY HAND THIS _____ DAY OF _____ 20____

MARGARITA HANCO
CITY CLERK AND CLERK OF THE CITY COUNCIL,
CITY OF SAN LEANDRO,
ALAMEDA COUNTY, CALIFORNIA

RECORDER'S STATEMENT:

FILED THIS _____ DAY OF _____ 20____ AT _____ AT THE REQUEST OF _____ IN BOOK _____ OF PARCEL MAPS, AT PAGE _____ OF OLD REPUBLIC TITLE COMPANY.

INDEXED _____
SERIES NUMBER _____
PARCELS COVERED _____
COUNTY RECORDED IN AND FOR THE COUNTY _____ ALAMEDA, STATE OF CALIFORNIA

BY: _____
DEPUTY COUNTY RECORDER

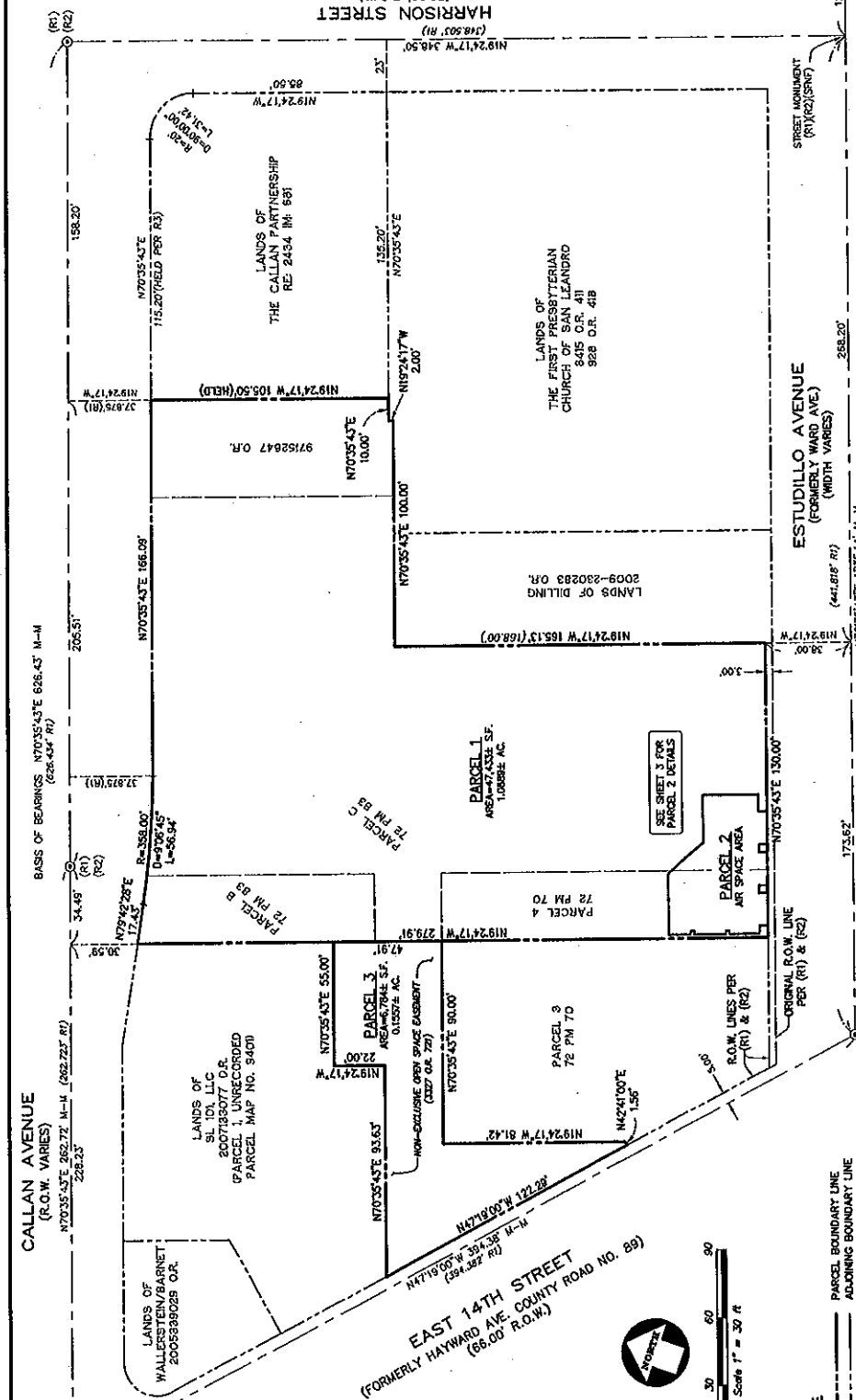

PARCEL MAP 10073

CITY OF SAN LEANDRO - ALAMEDA COUNTY - CALIFORNIA
JANUARY 2013

BEING A SUBDIVISION OF THOSE PARCELS OF LAND DESCRIBED IN THAT CERTAIN GRANT DEED RECORDED JUNE 13, 1972 ON REEL 338 AT PAGE 83 AND THAT CERTAIN GRANT DEED RECORDED JUNE 9, 1957 UNDER INSTRUMENT NUMBER 37162697; ALL OFFICIAL RECORDS OF ALAMEDA COUNTY.

KIER & WRIGHT
CIVIL ENGINEERS & SURVEYORS, INC.
1001 UNIVERSITY AVENUE, SUITE 400
OAKLAND, CALIFORNIA 94612
PHONE: (510) 245-4756
FAX: (510) 245-4796

JOB NO.: A1574-1

SHEET 2 OF 3 SHEETS

BASES OF BEARINGS:
FOUND MONUMENTS IN CALLAN AVENUE AS SHOWN ON PARCEL MAP NO. 802 FILED MAY 2, 1972 IN BOOK 72 OF PARCEL MAPS PAGE 83 TAKEN AS NORTH 70° 35' 43" EAST IS THE BASIS OF BEARINGS SHOWN HEREON.
CITY BENCHMARK
A GNCH MAIL IN THE TOP OF CATCH BASIN ON THE NORTHEASTLY CORNER OF CALLAN AVENUE AND EAST 14th STREET, ELEVATION = 55.965' (N01026)

NOTE:
PARCEL 3 IS AFFECTED BY A 10 FOOT WIDE POLE EASEMENT, RECORDED MAY 1, 2006, UNDER SERIES NO. 200614310, THE LOCATION OF SAID EASEMENT IS NOT DEPICTED IN SAID DOCUMENT AND IS NOT PLOTTED HEREON.

LEGEND:
 _____ PARCEL BOUNDARY LINE
 _____ ADJOINING BOUNDARY LINE
 _____ OLD LOT LINE
 _____ MONUMENT LINE
 ○ FOUND STREET MONUMENT, AS NOTED
 △ MONUMENT-TO-MONUMENT
 M-M MONUMENT-TO-MONUMENT LINE
 P.M. PARCEL MAP
 F.O.W. RIGHT-OF-WAY
 S.F.P. SQUARED FOOT NOT FOUND
 S.F. SQUARE FEET

MAP REFERENCE:
 (R1) PARCEL MAP NO. 802, 72 PM 83
 (R2) R.O.S. 457, 5 P.O.S. 57
 (R3) 69-58393 O.R.

DETAIL OF PARCEL 2
SCALE: 1" = 10'

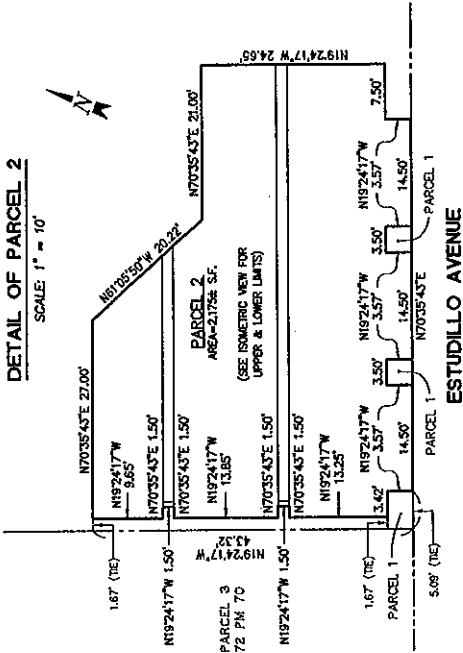

PARCEL 2
ISOMETRIC VIEW
NOT TO SCALE

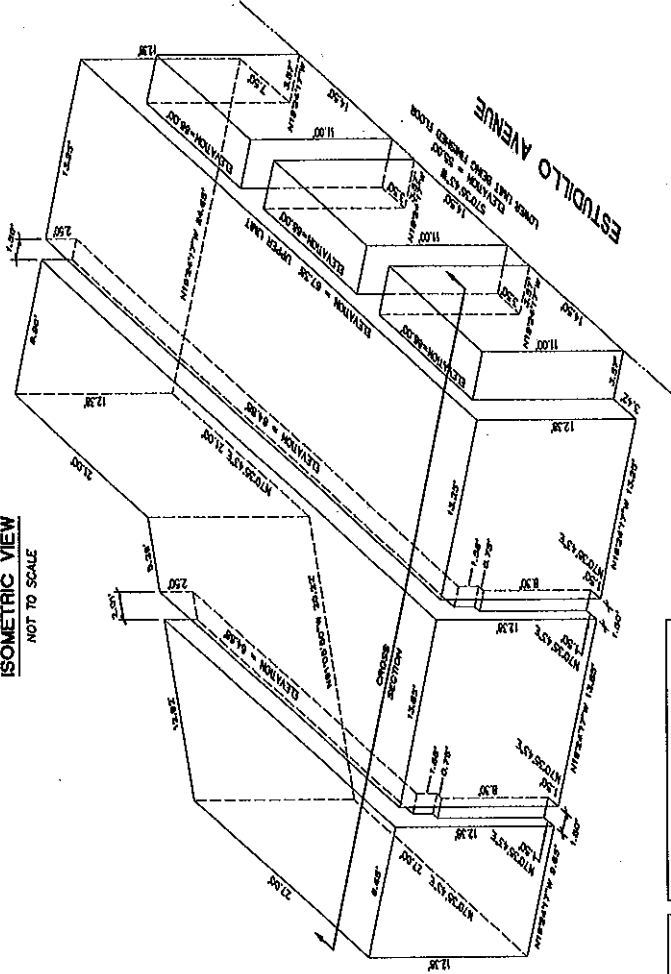

CROSS SECTION
SCALE: 1" = 5'

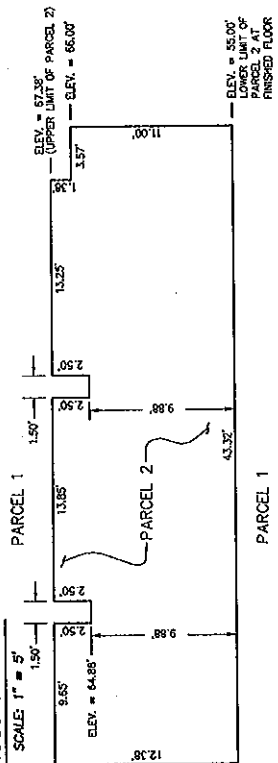

DETAIL
(COLUMN AND OVERHEAD BEAM)

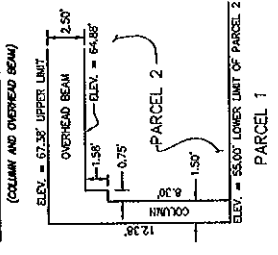

PARCEL MAP 10073

BEING A SUBDIVISION OF THOSE PARCELS OF LAND DESCRIBED IN THAT CERTAIN GRANT DEED RECORDED JUNE 13, 1972 OR REEL 318 AT PAGE 371 AND 372, AND THAT CERTAIN GRANT DEED RECORDED JUNE 6, 1977 UNDER INSTRUMENT NO. 37162847, ALL OFFICIAL RECORDS OF ALAMEDA COUNTY.

CITY OF SAN LEANDRO - ALAMEDA COUNTY - CALIFORNIA

JANUARY 2013
KIER & WRIGHT
CIVIL ENGINEERS & SURVEYORS, INC.
10000 UNIVERSITY AVENUE, SUITE 200
DUBLIN, CALIFORNIA 94568
TEL: (925) 344-9798
FAX: (925) 344-9798

Exhibit C

FORM OF GRANT DEED – CHAMBER CONVEYANCE TO CITY

**RECORDING REQUESTED BY
AND WHEN RECORDED, MAIL THIS
DOCUMENT AND TAX DOCUMENTS
TO:**

CITY OF SAN LEANDRO
835 East 14th Street
San Leandro, CA 94577
Attn: City Clerk

EXEMPT FROM RECORDING FEES PER
GOVERNMENT CODE §§6103, 27383

No documentary transfer tax is due per RT Code 11922-Government
Agency acquiring title

(SPACE ABOVE THIS LINE RESERVED FOR RECORDER'S USE)

GRANT DEED

For valuable consideration, receipt of which is hereby acknowledged, the San Leandro Chamber of Commerce, a California nonprofit public benefit corporation ("**Grantor**") hereby grants to the City of San Leandro, a municipal corporation, ("**Grantee**") all that real property located in the City of San Leandro, County of Alameda, State of California described in Exhibit C-1 attached hereto and incorporated herein.

IN WITNESS WHEREOF, Grantor has executed this Grant Deed as of
March 11, 2013.

GRANTOR:

SAN LEANDRO CHAMBER OF COMMERCE
A CALIFORNIA NONPROFIT PUBLIC BENEFIT CORPORATION

By: *Oliver Grodi*

Its: *Chairman of the Board of Directors*

EXHIBIT C-1 TO GRANT DEED

PROPERTY

Portion of Lots "H", "T", and "J", Block 1, Map of the Town of San Leandro, filed February 27, 1855, Map Book 1, page 19, Alameda County Records, bounded as follows:

Beginning at a point on the northwestern line of Davis Street, distant thereon North 62° 00' east 33 feet from the northeastern line of Hays Street, as said streets are shown on the said map, said point of beginning being distant north 62° 00' east 40.10 feet, more or less, along said line of Davis Street from the northeastern line of Hays Street, as now improved; and running thence along said line of Davis Street north 62° 00' east 52 feet; thence north 28° 00' west 197.92 feet; thence along the southeastern line of the parcel of land described in the deed to City of San Leandro, recorded September 5, 1957 in Book 8460 of Official Records of Alameda County, page 321, said line being the southeastern line of Hays Street, as now improved, south 42° 00' west 31.84 feet and southwesterly, on the arc of a tangent curve to the left, with a radius of 94.50 feet, a distance of 24.98 feet to a line drawn north 28° 00' west from the point of beginning; thence south 28° 00' east 175.71 feet to the point of beginning.

Assessor's Parcel Number: 075-0001-009-02

CERTIFICATE OF ACCEPTANCE

This is to certify that the interest in real property conveyed by the Grant Deed dated _____, 2012, from San Leandro Chamber of Commerce, a California nonprofit public benefit corporation to the City of San Leandro, a municipal corporation ("City"), is hereby accepted on behalf of the City by the undersigned officer or agent on behalf of the City Council of the City of San Leandro pursuant to authority conferred by resolution of the City Council adopted on _____, 20__, and that the City consents to recordation of the Grant Deed by its duly authorized officer.

Dated _____, 20__

CITY OF SAN LEANDRO

By: _____

Title: _____

APPROVED AS TO FORM:

By: _____
City Attorney

SIGNATURES MUST BE NOTARIZED.

Exhibit D

FORM OF GRANT DEED – CONVEYANCE OF OFFICE PARCEL TO CHAMBER

**RECORDING REQUESTED BY
AND WHEN RECORDED MAIL TO:**

SAN LEANDRO CHAMBER OF COMMERCE

Attn: _____

EXEMPT FROM RECORDING FEES PER
GOVERNMENT CODE §§6103, 27383

(SPACE ABOVE THIS LINE RESERVED FOR RECORDER'S USE)

GRANT DEED

For valuable consideration, receipt of which is hereby acknowledged, the City of San Leandro, a municipal corporation ("Grantor") hereby grants to the San Leandro Chamber of Commerce, a California nonprofit public benefit corporation ("Grantee") all that real property located in the City of San Leandro, County of Alameda, State of California described in Exhibit D-1 attached hereto and incorporated herein (the "Property").

The Property is conveyed subject to all terms, conditions, reservations of rights and easements set forth in that certain Reciprocal Easement Agreement and Declaration of Covenants, Conditions and Restrictions (Estudillo Parking Garage) dated as of _____, 2012, executed by and between Grantor and Grantee, and recorded in the Official Records of Alameda County on _____, 2013 as Instrument No. _____.

IN WITNESS WHEREOF, Grantor has executed this Grant Deed as of _____, 20__.

GRANTOR:

CITY OF SAN LEANDRO, A MUNICIPAL CORPORATION

By: _____

Its: _____

Exhibit D-1 to Grant Deed

Parcel 2 of Parcel Map 10073 recorded on _____
(this legal description will be completed when the Map is recorded)

Exhibit E

DECLARATION OF ONE AND ONLY RIGHT OF FIRST OFFER

THIS Declaration of one and only right of first offer (the "Declaration") is made this 11th day of March, 2013 by the San Leandro Chamber of Commerce, a California nonprofit public benefit corporation (the "Declarant").

WITNESSETH

A. By Agreement of Property Exchange and Indemnity with One and Only Right of First Offer (the "Agreement") dated _____ between the City of San Leandro (the "City"), and the San Leandro Chamber of Commerce, (the "Chamber"), City and Chamber agreed to exchange all that certain land described in the Agreement and Exhibits to the Agreement attached hereto; and

B. Pursuant to the Agreement, at closing, the Chamber was required to deliver to City a One and Only Right of First Offer relating to the Office Parcel, as more particularly described in Section 25 of the Agreement (and as more fully depicted in Exhibit D-1 of the Grant Deed between the City and the Chamber, attached hereto, and made a part hereof).

NOW THEREFORE, the Declarant, intending to be legally bound hereby and incorporating the foregoing recitals by reference, declares that the Office Parcel is and shall be subject to the covenants and rights hereinafter set forth.

1. Grant of One and Only Right of First Offer. The Declarant hereby irrevocably grants to City the following right (hereinafter the "One and Only Right of First Offer") with respect to the Office Parcel, which One and Only Right of First Offer hereby created shall constitute a covenant running with the land and shall be binding upon the Declarant's first initiative to sell said Office Parcel.,

(a) At any time or times after the date hereof that Declarant desires to sell the Office Parcel, or any portion thereof, to any person or entity (other than as provided below), Declarant shall first offer the Office Parcel, or the relevant portion thereof, as the case may be, once and only once, by written notice to City. Declarant's notice shall include the proposed sale price and other economic terms of the proposed sale (collectively the "Notice of Sale Terms"). The Parties shall then have forty-five (45) days (time being of the essence) after receiving the Notice of Sale Terms to notify Declarant in writing of City's election to purchase the Office Parcel, or the relevant portion thereof, as the case may be, in accordance with the conditions of the Notice of Sale Terms, such writing to be accompanied by a bank or certified check in an amount equal to five percent (5%) of the purchase price (the "Deposit"). If City does so elect to exercise its right to purchase the Office Parcel, or the relevant portion thereof, as the case may be, City shall:

(i) Proceed to and complete closing no later than sixty (60) days after the exercise of its right to purchase (time being of the essence); and (ii) promptly cooperate with Declarant to proceed to negotiate in good faith and execute an Agreement of Sale relating to the sale, although the failure of the Parties to agree on any terms or to actually execute an Agreement of Sale shall make null and void the Declarant's obligation to sell and the City's one and only right to purchase the Office Parcel, or the relevant portion thereof, as the case may be. City's notice of its election to exercise its right to purchase hereunder shall be ineffective unless it meets the requirements set forth above and is accompanied by the Deposit. If City shall fail to close the purchase as required above, Declarant shall return the Deposit to City and Declarant shall thereafter be free to sell the Office Parcel in accordance with Section 1(b) below.

(b) If City shall fail to validly and timely exercise such right to purchase or the parties fail to agree on terms, after notice by Declarant, as provided herein, such right shall be deemed to have lapsed and expired with respect to the Office Parcel or the relevant portion thereof, as the case may be, offered to City, and the Declarant may thereafter freely sell the Office Parcel or the relevant portion thereof, as the case may be (such a sale is hereinafter referred to as a "Permitted Sale"), at any time provided that Declarant shall not be permitted to sell the Office Parcel or the relevant portion thereof, as the case may be, on terms equal to or less favorable to Declarant than the term set forth in City's last offer, without first offering the Office Parcel to City on the same terms, and Section 1. (a) (i) above shall then apply to negotiating this offer. Should this "same terms" offer not be successfully negotiated, the One and Only Right of First Offer irrevocably lapses.

2. City To Cooperate With Declarant In Connection With Sales. City shall cooperate with Declarant in connection with the sale of the Office Parcel or any portion thereof to a third party which has either cleared the City's One and Only Right of First Offer or is an Exempt Sale (as that term is defined in the following Section 3) in order to demonstrate to the purchaser and/or the insurer of its title to the Office Parcel, or any portion thereof, that it is a Permitted Sale or an Exempt Sale, as the case may be. This obligation to cooperate shall include the City's obligation to execute such documents, in recordable form if requested, as are reasonably requested by the Declarant, its purchaser or the insurer of such purchasers' title to document the City's waiver of its One and Only Right of First Offer with respect to the subject sale or the fact that the subject sale is an Exempt Sale.

3. Sales By Declarant Which Are Not Subject to City's One and Only Right of First Offer. The following sales of the Office Parcel or any portion thereof (hereinafter referred to singularly as an "Exempt Sale" and collectively as "Exempt Sales") shall not be subject to City's Right of First Offer and may be freely sold by the Declarant without following the procedure set forth in Section 1 of this Declaration:

(a) A sale or sales to an affiliate or a development partner of Chamber provided that they are an affiliate or partner during the development of the Office Parcel; and

(b) A transfer or transfers made as part of the financing of the acquisition or development of the Office Parcel; and

(c) A transfer or transfers made pursuant to a bona fide deed in lieu of foreclosure made to the secured mortgagee of the Office Parcel or a portion thereof and/or a transfer made pursuant to a sheriff's sale in a mortgage foreclosure or other action.

Additionally, it is expressly understood that the transfer of an interest in the Office Parcel in a manner other than by a sale (for example, pursuant to a lease or the grant of a Mortgage) shall not trigger the City's Right of First Offer. Nor shall the subdivision or subjection to a condominium regime of the Office Parcel or any portion thereof trigger the City's Right of First Offer, although the subsequent sale of any subdivided portion or a condominium unit of the Office Parcel shall trigger the City's Right of First Refusal, unless it is an Exempt Sale.

5. No Liability for Obligations Accruing After Ownership. No owner of the Office Parcel or any portion thereof shall have any personal liability or responsibility for any obligation which accrues under this Declaration after the time that such party no longer is the owner of the relevant property.

6. Notice. Any notice given pursuant to this Declaration shall be valid only if given in writing and shall be deemed sufficiently given if given by registered or certified mail with sufficient postage attached, by overnight delivery service or hand delivery. Notices to City shall be sufficient if addressed to, or delivered to a person in charge at:

City of San Leandro, c/o City Clerk, City Hall, 835 East 14th Street, San Leandro, CA 94577

With a copy to:

City of San Leandro, c/o City Attorney, 835 East 14th Street, San Leandro, CA 94577

Notices to Declarant shall be sufficient if addressed to:

San Leandro Chamber of Commerce, 120 Estudillo Avenue, San Leandro, CA 94577
Attn: Chief Executive Officer

The date of delivery of any notice provided for in this Declaration shall be the date of deposit in the U.S. mails with sufficient postage if given by registered or certified mail and whether or not a return receipt is returned the date of deposit to the overnight delivery service, if so given, or the date of actual delivery to the above address of the party to be notified if hand delivered. The person and place to which notice may be given may be changed from time to time by City or Declarant respectively upon written notice to the other, effective five (5) days after delivery of such notice.

7. Modifications. City shall make modifications to this Declaration reasonably requested by any lender to Declarant, or any successor or assign of Declarant, to enable the Office Parcel to be financed, such modification or amendment not to be unreasonably denied, delayed or conditioned, provided that City shall not be required to make any modification which materially and adversely affects any right of City under this Declaration.

IN WITNESS WHEREOF, the Declarant has duly executed this Declaration as of the day and year first above written.

By: David Meodi Date: 3-11-13

Its: Chairman of the Board of Directors

Declarant, San Leandro Chamber of Commerce

CALIFORNIA ALL-PURPOSE ACKNOWLEDGMENT

State of California

County of Alameda }

On 3/11/13 before me, Tara H. Peterson, Notary Public
Date Here Insert Name and Title of the Officer

personally appeared David P. Johnson and
Name(s) of Signer(s)

David Grodin

who proved to me on the basis of satisfactory evidence to be the person(s) whose name(s) is/are subscribed to the within instrument and acknowledged to me that he/~~she~~/they executed the same in his/~~her~~/their authorized capacity(ies), and that by his/~~her~~/their signature(s) on the instrument the person(s), or the entity upon behalf of which the person(s) acted, executed the instrument.

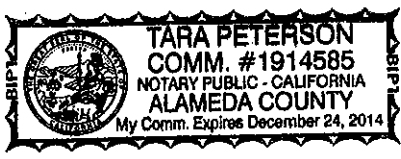

I certify under PENALTY OF PERJURY under the laws of the State of California that the foregoing paragraph is true and correct.

WITNESS my hand and official seal.

Signature Tara H. Peterson
Signature of Notary Public

Place Notary Seal Above

OPTIONAL

Though the information below is not required by law, it may prove valuable to persons relying on the document and could prevent fraudulent removal and reattachment of this form to another document.

Description of Attached Document

Title or Type of Document: Property Exchange and Indemnity Agreement

Document Date: 3/11/13 Number of Pages: 29

Signer(s) Other Than Named Above: _____

Capacity(ies) Claimed by Signer(s)

Signer's Name: _____

- Individual
- Corporate Officer — Title(s): _____
- Partner — Limited General
- Attorney in Fact
- Trustee
- Guardian or Conservator
- Other: _____

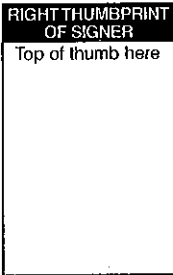

Signer Is Representing: _____

Signer's Name: _____

- Individual
- Corporate Officer — Title(s): _____
- Partner — Limited General
- Attorney in Fact
- Trustee
- Guardian or Conservator
- Other: _____

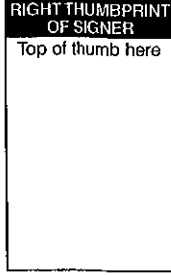

Signer Is Representing: _____

Mail tax statements to the address below.

RECORDING REQUESTED BY
AND WHEN RECORDED RETURN TO:

City of San Leandro
835 East 14th Street
San Leandro, California 94577-3767
Attention: City Clerk

Exempt from Recording Fees per Government Code
§§6103, 27383

(Space Above This Line For Recorder's Use Only)

**RECIPROCAL EASEMENT AGREEMENT AND DECLARATION OF
COVENANTS, CONDITIONS, AND RESTRICTIONS**

(Estudillo Parking Garage)

This Reciprocal Easement Agreement and Agreement of Covenants, Conditions, and Restrictions (this "**Agreement**") is executed as of _____, 2013 ("**Effective Date**") by and between the City of San Leandro, a municipal corporation ("**City**") and the San Leandro Chamber of Commerce as the current owner of Parcel 2, a California nonprofit public benefit corporation ("**Chamber**"). City and Chamber are referred to collectively herein as the "**Parties**."

RECITALS:

A. City is the owner of the real property located at 120-122 Estudillo Avenue in the City of San Leandro, Alameda County, State of California and more particularly described in Exhibit A attached hereto and incorporated herein (the "**Property**"). The Property is improved with a four-story public parking garage consisting of approximately 47,434 square feet (the "**Garage**"), which includes approximately 2,175 square feet of commercial office space (the "**Office**").

B. City intends to subdivide the Property into two parcels as depicted on Parcel Map 10073 attached hereto as Exhibit A (the "**Map**"). Each parcel is herein referred to individually as a "**Parcel**" and collectively the parcels are referred to as the "**Parcels**." As used herein, "**Parcel 2**" means Parcel 2 of the Parcel Map that will be conveyed to Chamber by separate instrument, and which consists solely of the Office. "**Parcel 1**" means Parcel 1 of the Parcel Map which will be retained by the City, and which includes the Garage and the land that underlies the Office and the Garage.

C. The Parties desire the Property to be managed and operated in a uniform manner, and to subject the Parcels to the easements and the covenants, conditions, and restrictions as hereinafter set forth.

D. This agreement is in accordance with Resolution No. 2008-023 RDA passed by the Members of the Redevelopment Agency for the City of San Leandro on 9/28/2008.

NOW, THEREFORE, the Parties intend to, and do hereby, establish certain reciprocal easements, covenants and conditions with respect to the Parcels and the Property as follows:

1. Definitions.

“Environmental Laws” means any and all present and future federal, state, and local laws (whether under common law, statute, rule, regulation or otherwise), regulations, rules, guidelines, and ordinances relating to human health, safety, pollution, and protection of the indoor or outdoor environment or otherwise relating to the presence, manufacture, processing, distribution, use, treatment, storage, release, transport, handling, record keeping, notification, disclosure, and reporting requirements of and relating to Hazardous Substances, including, without limitation, the Comprehensive Environmental Response Compensation and Liability Act, the Resource Conservation and Recovery Act, the Clean Water Act, the Clean Air Act, and the Occupational Safety and Health Act, each as may be amended from time to time.

“Garage” is defined in Recital A.

“Hazardous Substance” means hazardous wastes, hazardous chemicals, flammable or explosive materials, biological and medical waste, radioactive materials, toxic materials or related materials (whether potentially injurious to persons or property and whether potentially injurious by themselves or in combination with other materials), including, but not limited to, any waste, chemical, substance or material now or hereafter determined by any federal, state or local governmental agency or authority having jurisdiction to be hazardous to human health or the environment or which is or becomes regulated by such agency or authority (including, but not limited to, those materials listed in the United States Department of Transportation Hazardous Materials Table as amended from time to time and gasoline, other petroleum based products and any fractions thereof), which are released to the environment, including, without limitation, the soil, groundwater and/or air, at, under or above the Property or any part thereof or the structures located thereon.

“Laws” means all laws, statutes, ordinances, codes, rules, and regulations of local, state, and federal governmental authorities, including those relating to public health and safety, access for persons with disability, fire safety, and building codes, and further including Environmental Laws.

“Lessee” means any lessee, sublessee or occupant of any building space within the Property, or any ground lessee, sublessee or occupant of any land within the Property.

“Losses” means, collectively, claims, demands, actions, suits, proceedings, losses, liabilities, damages, judgments, costs, and expenses, including reasonable attorneys’ fees and costs.

“Map” is defined in Recital B.

“Owner” means the party that from time to time is the fee simple owner of a Parcel.

“Parcel” is defined in Recital B.

“Parcel Users” means any Owner and its Lessee’s and their respective principals, employees, agents, representatives, contractors and invitees and the Owner’s successors and assigns.

“Property” is defined in Recital A.

“Release” means a release of any Hazardous Substance in, on, under or about the Property in violation of any Environmental Law.

“Utility Facilities” is defined in Section 3.3.

“Violation” means any violation of Environmental Laws.

2. Development, Use, and Operations.

2.1 Development. City, at its sole cost and expense, shall have responsibility for completing construction of the Garage, Office, and improvements as delineated on the Plans and Specifications entitled “Estudillo Callan 2008 Parking Garage, Project Number 08-962-86-067”, dated June 2010 (the “City Plans”) as depicted on the Record Drawings, when they are available. There shall be no modification to the City Plans which modify, affect or impact Parcel 2, the Office and/or the improvements constructed thereon without the written approval of the Owner of Parcel 2. The Parties acknowledge that the Map creates Parcel 2 as an “air space” parcel which consists of approximately 2,175 square feet on the ground floor of the Garage fronting on Estudillo Avenue, bounded by the interior unfinished surfaces of perimeter walls, foundations, floors and ceilings bounding Parcel 2, as more particularly described in Exhibit A.

2.2 Use. The Property shall be used as permitted by the City of San Leandro Zoning Ordinance as amended from time to time, and no use shall be established that would cause a default or breach of this Agreement.

2.3 Restricted Uses. No Parcel User shall create or continue any nuisance, disturbance or other condition which could reasonably be expected to adversely affect another Parcel User’s enjoyment of its premises.

2.4 Property Not Subject to Davis-Stirling Act. The Parties acknowledge that the Property is not subject to the provisions of the Davis-Stirling Common Interest Development Act (California Civil Code Section 1350 *et seq.*) by virtue of the fact that, among other reasons, there

are no common areas as defined in Civil Code Section 1351(b), and there will be no Owner's association (as defined in Civil Code Section 1351(a)).

3. Grant of Easements; Encroachments.

3.1 Waste Room. City grants to the Parcel 2 Parcel Users, an exclusive easement of access, ingress and egress over the Waste Room for Parcel 2, located on Parcel 1 as shown on Exhibit B (the "**Waste Room**"). The Waste Room is approximately 111.57 square feet, and is strictly for the storage of waste until collected by the applicable waste removal service as provided below. Flammable or Hazardous Substances in violation of Environmental Laws shall not be disposed of in the Waste Room. Waste and recycling containers must be stored in the Waste Room at all times except for the purpose of servicing them on collection days where they may be placed at the curb for a period no longer than 24-hours. Owner of Parcel 2 or Parcel 2 Parcel Users shall store waste in accordance with Chapter 3-6 of the San Leandro Municipal Code, and shall without limitation, do all of the following: 1) subscribe to regular solid waste and recycling services from the City's franchisee; 2) deposit waste materials in one or more leak-proof containers of sufficient size and quantity to adequately service the property, as provided by the City's franchisee; 3) contain waste materials in a manner so as to discourage disturbance by, or harboring of, animals or pests; to prevent fire or other safety hazards, and to prevent odors or unsightliness amounting to a nuisance; 4) refrain from storing or accumulating any putrescible waste on site for a period longer than seven (7) days; 5) refrain from storing Hazardous Substances, medical and infectious waste, or special waste, in the Waste Room; and 6) refrain from using City litter cans for disposing of waste materials originating from Parcel 2. The Waste Room also houses the Electrical Disconnect Panel for Parcel 2. Panel clearance shall be maintained at all times per City and Fire Codes.

3.2 Mechanical Equipment Area. City grants to the Parcel 2 Parcel Users an exclusive easement of access, ingress, and egress over the fenced area on Parcel 1 shown on Exhibit "B" to install, operate, maintain, and replace Heating Venting Air Conditioning mechanical equipment (HVAC), and such other equipment (vacuums, redundant power, generators etc.) that may be installed with the prior written approval of the City for the benefit of Parcel 2, (the "**HVAC Equipment Area**"). The HVAC Equipment Area is approximately 412.85 square feet. The Owner of Parcel 2 shall be responsible to maintain the equipment, including the fencing that surrounds the HVAC Equipment Area, in good working order and free of debris or other materials not specifically required in the maintenance or operation of the HVAC equipment. Owner of Parcel 2 shall ensure that the HVAC Equipment Area remains locked at all times and shall not allow the area to be used for storage of any kind.

3.3 Parking Spaces. City grants to the Parcel 2 Parcel Users an exclusive easement to park vehicles, with no cost or other charges to the owner of Parcel 2, within the designated parking area located on Parcel 1 as shown on Exhibit B (the "**Parcel 2 Parking Area**"). The Parcel 2 Parking Area is approximately 486 square feet. Owner of Parcel 2 shall be responsible for striping, signage, surface maintenance, and cleanup of the Parcel 2 Parking Area, however the Owner of Parcel 2 shall not be responsible for the maintenance, repair or replacement of any structural portions of the Parcel 2 Parking Area. No storage of vehicles or any other item is permitted, nor is any overnight parking allowed other than by Parcel 2 Parcel Users working on

Parcel 2 during such hours. No vehicle maintenance is permitted. The Owner of Parcel 2 is responsible for the enforcement of its own parking restrictions for the Parcel 2 Parking Area, including striping and signage, provided such striping and signage complies with City standards. The City shall maintain all access drives, drive lanes and walkways providing access to the Parcel 2 Parking Area in an unobstructed and safe condition.

3.4 Ingress, Egress, Access. City grants to the Parcel 2 Parcel Users nonexclusive easements across all driveway, drive lane, walkway and other public access areas on Parcel 1 as reasonably necessary for pedestrian and vehicular access, ingress and egress to areas described in Sections 3.1, 3.2 and 3.3.

3.5 Utility and Service Easements. Each Party, as grantor with respect to its Parcel, hereby grants to the other Party, and its successors and assigns for the benefit of its Parcel, a nonexclusive easement over the grantor's Parcel to install, maintain, repair, and replace Utility Facilities serving the other Party's Parcel. "Utility Facilities" means utility facilities for drainage and sanitary sewer drainage, storm drainage, gas, water, electricity, and other forms of energy, communication, cable television, or electrical conduits, lines, pipes or systems, and other utilities necessary for the development and operation of the improvements located on the Property, including, but not limited to, sanitary and storm sewers, drainage, gas and water mains, fire hydrants or other fire protection installations, electric power, cable television, and communication conduits. The rights granted pursuant to such easements will at all times be exercised in such manner as to cause the least interference with the rights of the other Owner and with the normal operation of the Property. Each Owner making or causing the installation of any Utility Facilities shall, at its expense, completely restore to the previously existing or better condition all improvements and surfaces disrupted as a result of such installation. In the event it should be necessary to grant any of the foregoing easements and rights to local utility companies as a condition of their providing or continuing service, such rights will be granted at no cost so long as the Owner required to execute such instruments deem the terms and conditions of such grant to be reasonably acceptable.

3.6 Encroachments. Each Owner shall have rights of access over the Parcel of the other Owner for the purpose of accommodating minor encroachments of any improvements that are built in accordance with the City Plans, or which arise due to inadvertent error in engineering, design or construction settlement or shifting of the building, or similar causes; provided that the foregoing shall not apply to intentional misconduct of the City or any of its agents or employees. In the event any of the original improvements constructed by City on the Property are partially or totally destroyed, and then repaired or rebuilt in accordance with the City Plans, the Owner of Parcel 2 agrees that minor encroachments (meaning encroachments that do not reduce the interior square footage of the Office by more than 2%) over Parcel 2 shall be permitted and that there shall be valid rights of access for the maintenance of said encroachments so long as they shall exist. In the event that an error in engineering, design or construction (that was inadvertent on the part of the City) results in an encroachment of any of the original improvements constructed by City into Parcel 2, or into a required setback area, a correcting modification may be made in the Map, provided that such correction shall not reduce the interior square footage of the Office more than 2%. Said modification shall be in the form of a certificate of correction and shall be executed by the Parcel 2 Owner and the City (so long as

City is the sole owner of the Garage) and by City's engineer, or the City Engineer, whichever is applicable. There shall be no valid rights of access for any encroachment except as provided above in this Section.

The City grants a permanent encroachment for air-space for the maintenance of the louvers and installation and maintenance of signage and appurtenance that are within Parcel 1 and/or the public right-of-way. The louvers and signage shall be located within the space of the encroachment as defined in Exhibit C and labeled louver and signage encroachment. Owner of Parcel 2 acknowledges that there are no rights to install or construct any improvements in the public right-of-way at ground level. The Owner of Parcel 2 is the owner of the louvers and their structures adjacent to Parcel 2 and its identifying signage, and has the right to construct, maintain, upgrade, replace, remove, and operate the louvers and signage and appurtenances in the air-space encroachment. However, the Owner of Parcel 2 must obtain the approval of the City prior to making any visible changes to the louvers, their structures, and the signage. Since the louvers and their structures match others around the garage structure, the Owner of Parcel 2 shall maintain them in a similar manner to those belonging to the City to retain the unifying appearance. Prior to commencement of any construction, maintenance, upgrade, replacement or removal of facilities within the air-space encroachment which requires the use of the public right-of-way outside of Parcel 2's encroachment, the Owner of Parcel 2 or its agents shall apply for an encroachment permit from the City and meet all permit requirements.

The provisions of Section 9.2 Liability Insurance shall apply to all Parcel 2 facilities and operation within the air-space encroachment in the public right-of-way.

3.7 Public and Other Easements. Each Parcel shall also be subject to nonexclusive easements for public utility location and maintenance, public service access, and emergency service access in favor of the City, and as may be required by the City in connection with the approval of the Map or otherwise with respect to the development of the Property.

3.8 Foundation and Continued Support. City grants to the Owner of Parcel 2, subject to the terms, provisions and limitations of this Agreement, non-exclusive easements constituting the right to receive, use and maintain continuous support from the Parcel 1 and the improvements located within Parcel 1, as may be necessary for the development, existence, use and enjoyment of Parcel 2, including, without limitation, support for all improvements within Parcel 2 and the right to obtain substantial load-bearing support from exterior walls, foundations, footings, slabs, floors, ceilings, posts, columns and any other elements providing or that will provide a foundation or structural support for all or any portion of Parcel 2.

4. Maintenance.

4.1 Maintenance. The Parties acknowledge and agree that there are no "common areas" associated with the Property. Each Party shall be responsible for maintenance, at its own expense (except as expressly set forth herein), of the improvements located on or within the Parcel such Party owns. For purposes of clarification, it is intended that Parcel 2 be an air space parcel which will not include any structural improvements. Without limiting the generality of the foregoing: (i) City shall retain responsibility for maintenance, repair, and replacement of all structural elements of the Garage (including, without limitation, all Garage exterior walls,

foundation and roof) regardless of whether such structural components are located in whole or in part within Parcel 2 and the sidewalks and landscaping adjacent to the Garage, and (ii) the Owner of Parcel 2 shall be responsible for maintenance, repair, and replacement of the following improvements within Parcel 2: Interior surfaces of structural walls and interior surfaces of ceilings, all portions of non-structural walls, floor coverings (but not foundation), all Utility Facilities serving Parcel 2, repair and replacement of interior finishes, all interior improvements, all equipment affixed to interior finishes and non-structural walls and floors and ceilings, dropped ceilings, all windows and the adjustable solar louvers in the exterior canopy. Notwithstanding the foregoing, no Owner without the prior written consent of the other Owner, shall alter or improve (or permit any Parcel User to alter or improve) all or any portion of the Owner's Parcel in any manner that may compromise, or adversely impact or affect the other Parcel or any easements granted in this Agreement for the benefit of the Owner of the other Parcel.

4.2 Exterior Maintenance. Each Owner agrees to maintain, as needed and at its sole cost and expense, the exterior of the improvements on its Parcel in a clean, graffiti free, visually attractive, safe and sanitary condition, all consistent with the standards of a first class project, however, as to the Parcel 2 Owner the foregoing shall not apply to the repair or replacement of any improvements that are the responsibility of the City under Section 4.1 above. The Owners shall each have the right to bring an enforcement action to bring the defaulting Owner into compliance with the requirements of this Section. The Owner of Parcel 2 agrees for itself and its successors in interest that if the improvements located on Parcel 2 are completely or partially unoccupied, it shall nonetheless: (i) maintain the windows in a clean condition, removing any graffiti or etching promptly and cleaning the windows regularly; (ii) not board up or cover the windows of the improvements located on Parcel 2; and (iii) regularly inspect such improvements and take such steps as are reasonably needed to keep the improvements from becoming an eyesore or a target for vandalism or squatters. Except as otherwise provided in Section 8, the Owner of Parcel 2 shall not modify or alter the exterior appearance of the Parcel 2 improvements without City's prior written consent.

4.3 Standards. Each Owner at its own cost and expense shall keep, maintain, repair, and operate the improvements located on such Owner's Parcel which are the responsibility of such Owner to maintain pursuant to Section 4.1 or 4.2 above, whether occupied or unoccupied, in compliance with all applicable Laws and in good and clean order, operation, condition, and repair in conformity with first-class standards, in such a manner as to establish, maintain, and present, at all times, the appearance of a clean, well-painted, well-managed, and attractive property. In addition, the Owner of Parcel 2 agrees to refrain from storing boxes, files, equipment, etc. that is visible from the exterior windows. In addition, the ceiling of Parcel 2 shall not be penetrated or pierced (except by heating, air conditioners and other penetrations initially installed by the City in accordance with the City Plans) nor shall there be any other modification of improvements within Parcel 1 that would materially increase the transmission of sound or vibration into any Parcel 2.

4.4 Failure to Maintain. If any Owner (the "Failing Owner") fails to maintain such Owner's Parcel in accordance with this Agreement the other Owner may deliver to Failing Owner written notice of such failure, which written notice shall describe in detail the failure and

the actions required to cure such default hereunder. If the Failing Owner fails to commence the cure of such default within ten (10) business days after receipt of such written notice or after commencing such cure the Failing Owner fails to diligently prosecute such cure to completion, then other Owner may take all such actions as reasonably necessary to cure the default, including, without limitation entry on the Parcel of the Failing Owner and curing such default, and any direct third party costs incurred by the other Owner in connection with such cure, upon demand to Failing Owner, shall be due and payable to the other Owner from Failing Owner within ten (10) days after the Failing Owner receives written demand for payment from the other Owner which shall include third party invoices reflecting incurred costs. Interest at the maximum rate allowed by Law shall accrue and be payable on any such amount not paid in accordance with the preceding sentence from the date due until paid.

4.5 Reservation of Right to Assign Obligations. City shall have the right to assign its maintenance, operation, and repair obligations under this Agreement to a successor or to a property manager in the exercise of City's sole discretion.

4.6 Construction Activities. Each Owner agrees that all construction, alteration, remodeling, and reconstruction performed by or on behalf of such Owner on its Parcel shall be in compliance with this Agreement and all applicable Laws and codes. Each Owner agrees that all improvements constructed by it on its Parcel shall be constructed in a good and workmanlike manner, using prime quality materials and only after notifying the other Owner 30 days in advance of any activities that may impact the other, emergency repairs excepted.

5. Locations. The Owner of Parcel 2 shall not be permitted to construct improvements outside of Parcel 2 except as otherwise authorized in this Agreement.

6. Compliance With Laws; Hazardous Substances. Owner shall comply with all Laws applicable to its Parcel and the improvements located thereon at its sole cost. Each Owner shall maintain its Parcel at all times so as to comply with and conform to all Laws. Each Owner shall be responsible, at its sole cost, for compliance with any and all Environmental Laws applicable to its Parcel. If a Release or Violation affecting the Property occurs on a Parcel, then the Owner of the Parcel on which the Release or Violation occurred shall, at no cost to the other Owner, promptly remove or remediate the Release or Violation, in each case to the extent required by and in full compliance with Laws and shall indemnify and hold harmless the other Owner(s) from and against any and all Losses arising out of or in connection with a Release or Violation affecting the Property. Notwithstanding the foregoing, if such a Release or Violation on a Parcel was caused by the Owner or Parcel User of the other Parcel, then the Owner of such other Parcel shall at no cost to the Owner of the Parcel affected, promptly remove or remediate the Release or Violation, in each case to the extent required by and in full compliance with Laws, and shall indemnify and hold harmless the Owner of the Parcel affected from and against any and all Losses arising out of or in connection with such Release or Violation.

7. Taxes. Each Owner agrees to pay or cause to be paid, prior to delinquency, directly to the appropriate taxing authorities, all real property taxes and general and special assessments (including any special assessment, district assessments or similar funding mechanism promulgated by the governmental authority) which are levied against the Parcel and

improvements owned by such Owner. Taxes shall include, without limitation, assessments and fees levied with respect to any special assessment district within which the Property is located.

8. Signs. No signs, temporary or permanent, including animated or electronic copy/messages, shall be located on the structure (except signs identifying businesses conducted therein and located per Section 3.6 and directional parking and informational signs either installed or approved by the City). All signage shall be in compliance with all applicable laws and City requirements based on the "Downtown San Leandro Design Guidelines and Principles (2007)" that may be amended from time to time, and shall be subject to the prior approval of City.

9. Indemnification and Insurance.

9.1 Indemnification. Each Owner, and its successors and assigns, hereby agrees to defend, indemnify, and hold the other Owner and its members, managers, officers, directors, officials, employees, representatives, consultants, and contractors harmless from and against any and all liability, damage, expense (including reasonable attorneys' fees), causes of action, suits, claims or judgments arising from personal injury, death or property damage occurring on or from its own Parcel, except to the extent caused by the act or negligence of the indemnified party. Each Owner covenants and agrees to keep or cause to be kept their respective Parcel(s) and the improvements thereon, free and clear of and from any and all mechanics', materialmen's, and other similar liens arising out of or in connection with the operations thereon or other activities undertaken by such Owner or others claiming under such Owner, and to pay and discharge when due any and all lawful claims upon which any such lien may or could be based, and to save and hold the other Owner's Parcel(s) and the improvements thereon, free and harmless of and from any and all such liens and any and all claims of liens and suits or other proceedings pertaining thereto.

9.2 Liability Insurance.

(i) Coverage. Each Owner shall procure and maintain in full force and effect throughout the period of its ownership of a Parcel, commercial general liability insurance (or its equivalent) on an occurrence basis, in combined policy limits of not less than One Million Dollars (\$1,000,000) per occurrence and Two Million Dollars (\$2,000,000) in the aggregate, with commercially reasonable deductibles, insuring the Owner (as named insured) and the other Owner (as additional insureds) against all claims, demands, actions, suits or proceedings initiated or made by or for any person as a result of bodily injury (including death), personal injury or property damage (i) occurring upon, in, or about such Owner's Parcel or (ii) arising from any acts or omissions of such Owner or any of its agents or employees. Such insurance may be written by additional premises endorsement on any master policy of insurance carried by the Owner which may cover other property in addition to the property covered by this Agreement.

(ii) Liability Insurance Requirements. All commercial general liability insurance policies shall insure for contractual indemnity and contain a cross-liability endorsement. All insurance coverage required to be carried under this Section 9.2 shall be carried with insurance companies that are (i) licensed to do business in California, and (ii) rated in the then-most current Best's Insurance Guide (or any successor thereto) as having a general

policyholder rating of A or better and a financial rating of "VIII" or better. All insurance policies required to be carried by either Party shall be effected under standard form policies. Such insurance shall provide that the same may not be canceled without thirty (30) days prior written notice to the other Owner. The Owners shall each provide to the other Owner certificates evidencing the fact that such insurance has been obtained. Additionally, upon the request of either Owner, and provided that such request shall be commercially reasonable taking into account the standard practices at comparable properties in the area and if economically feasible for other Owner as reasonably determined by the other Owner, the other Owner shall increase the limits of insurance carried by it hereunder, and shall carry types of insurance in addition to those required hereunder, to the extent such additional types of coverage first become standard at comparable properties after the date hereof. No Owner shall carry any insurance concurrent in coverage and contributing in the event of loss with any insurance required to be furnished by the other Owner if the effect of such separate insurance would be to reduce the coverage of, or recovery available under, the other Owner's insurance.

9.3 Property Insurance.

(i) At all times during its ownership of a Parcel, each Owner shall maintain or cause their respective Lessees to maintain "all risks" property insurance (or its equivalent) covering all improvements located on such Owner's Parcel in a minimum amount equal to 100% of the reasonable replacement cost thereof.

(ii) Property Insurance Requirements. All property insurance policies shall contain a severability of interests clause. All insurance coverage required to be carried under this Section 9.3 shall be carried with insurance companies that are (i) licensed to do business in California and (ii) rated in the then-most current Best's Insurance Guide (or any successor thereto) as having a general policyholder rating of A or better and a financial rating of "VIII" or better. All insurance policies required to be carried by either Owner shall be effected under standard form policies. Such insurance shall provide that the same may not be canceled without thirty (30) days prior written notice to the Owner. The Owners shall each provide to the other certificates evidencing the fact that such insurance has been obtained. Additionally, upon the request of either Owner, and provided that such request shall be commercially reasonable taking into account the standard practices at comparable properties in the area and if economically feasible for other Owner as reasonably determined by the other Owner, the other Owner shall increase the limits of insurance carried by it hereunder, and shall carry types of insurance in addition to those required hereunder, to the extent such additional types of coverage first become standard at comparable properties after the date hereof.

(iii) Waiver. Each Owner hereby waives, and releases the other Owner from, any and all claims, liabilities, and rights of action with respect to any property loss caused by the other Owner which is covered by the property insurance required to be maintained by the first Owner. Each Owner hereby agrees that any property insurance maintained by it shall contain a waiver by the insurer of any and all rights of subrogation against the other Owner.

10. Damage/Destruction.

10.1 Utility Facilities. In the event of any damage to the Utility Facilities, the Owner of the Parcel served by the Utility Facilities shall promptly repair the damage and restore the Utility Facilities as near as possible to their condition existing prior to the damage; unless such damage was caused by the Owner of the other Parcel or its Parcel Users in which case such other Owner shall be responsible for the cost of such repair and/or restoration. The foregoing shall not apply to those portions of Utility Facilities that the utility companies or public utility districts providing the utilities are obligated to rebuild or repair.

10.2 Damage and Destruction. Upon any damage or destruction to any portion of the Garage and its appurtenant improvements, other than improvements which are the responsibility of the Parcel 2 Owner to maintain under this Agreement (the "**City Improvements**"), the City shall, at its sole cost and expense, promptly and diligently cause the repair or rebuilding of such City Improvements to a condition at least equal to that which existed immediately prior to the event causing such damage or destruction. Upon any damage or destruction to any portion of the improvements that are to be maintained by the Parcel 2 Owner under this Agreement (the "**Parcel 2 Owner Improvements**") the Parcel 2 Owner shall, at its sole cost and expense, promptly and diligently cause the repair or rebuilding of such Parcel 2 Owner Improvements to a condition at least equal to that which existed immediately prior to the event causing such damage or destruction.

11. Eminent Domain.

(a) Owner's Right to Award. Nothing herein shall be construed to give any Owner any interest in any award or payment made to another Owner in connection with any exercise of eminent domain or transfer in lieu thereof affecting said other Owner's Parcel or giving the public or any government any rights in said Parcel. In the event of any exercise of eminent domain or transfer in lieu thereof of any improvements located on any Parcel, the award attributable to the land and improvements shall be payable only to the Owner thereof.

(b) Lessee's Claim. Only as between an Owner and a Lessee of that Owner's Parcel, nothing in this Section shall supersede or control over the terms and the provisions of any lease between such Owner and such Lessee relating to the disposition or right to seek any awards in connection with any condemnation or eminent domain proceeding regarding the Parcel in question.

(c) Buildings. The Owner of any portion of improvements so condemned shall (i) repair and restore the remaining portion of the building on its Parcel to a safe and usable condition for retail use or (ii) raze the building, remove all rubble and debris, and place the building area in a safe and sightly condition.

12. Rights and Obligations of Lenders. Any holder of a mortgage lien on any Parcel (the "**Mortgagee**") who acquires title to such Parcel (or any Person who acquires title to such Parcel upon foreclosure by such lienholder), and any assignee or successor in interest of such first lienholder or Person, shall be subject to the terms and conditions of this Agreement. Nothing in this Agreement nor any amendment hereto, and no breach of any covenant, condition or restriction contained in this Agreement or any amendment hereto, shall render the lien of any mortgage, deed of trust or other security agreement or instrument invalid; provided that, such

Mortgagee shall take title to the Parcel or portion thereof subject to the obligations under this Agreement. Any Mortgagee, upon written request to an Owner, shall be entitled to receive written notification from such Owner of any default in the performance of the obligations imposed by this Agreement by the Owner whose Parcel is encumbered by such Mortgagee's mortgage concurrently with the delivery of such notice to the defaulting Owner; provided, however, an Owner shall only be obligated to provide such notice to Mortgagees who have delivered a written request therefor to the Owner specifying the Parcel to which such request relates. In addition to the foregoing, any Mortgagee who has delivered to an Owner the written notification described in the preceding sentence shall have the right to receive written notice of the expiration of any cure period applicable to any default by the Owner whose Parcel secures the Mortgagee's mortgage, and such Mortgagee shall be provided with not less than ten (10) business days after the delivery of such second notice to the Mortgagee to cure such default on behalf of its mortgagor prior to the other Owner's enforcement of its right to foreclose upon the defaulting Owner's Parcel pursuant to this Agreement.

(c) As used in this Agreement, the term "Mortgage" shall mean any duly recorded mortgage or deed of trust encumbering a Parcel, and the term "Mortgagee" shall mean the mortgagee or beneficiary under any Mortgage.

(d) The Owners, without the obligation to take on any financial or other liability, hereby agree to and will reasonably cooperate with each other and execute any and all documentation that may be requested by the other in order to facilitate the obtaining of a Mortgage on such Owner's Parcel.

13. Obligation to Refrain from Discrimination. There shall be no discrimination on the basis of race, color, religion, creed, sex, sexual orientation, marital status, ancestry or national origin in the hiring, firing, promoting or demoting of any person engaged in construction work in the Property, and each Owner and tenant shall direct its contractors and subcontractors to refrain from discrimination on such basis. Additionally, each Owner and Lessee shall not restrict the rental, sale, lease, sublease, transfer, use, occupancy, tenure or enjoyment of the Property, or any portion thereof, on the basis of race, color, religion, creed, sex, sexual orientation, disability, marital status, ancestry, or national origin of any person. City covenants for itself and all persons claiming under or through it that there shall be no discrimination against or segregation of any person or group of persons on account of any basis listed in subdivision (a) or (d) of Section 12955 of the Government Code, as those bases are defined in Sections 12926, 12926.1, subdivision (n) and paragraph (1) of subdivision (p) of Section 12955, and Section 12955.2 of the Government Code, in the sale, lease, sublease, transfer, use, occupancy, tenure or enjoyment of the Property or part thereof, nor shall any City or any Owner or tenant, or any person claiming under or through any of them respectively, establish or permit any such practice or practices of discrimination or segregation with reference to the selection, location, number, use or occupancy of tenants, lessees, subtenants, sublessees or vendees in, of, or for the Property or part thereof. Each Owner and tenant shall include this provision in all deeds, leases, contracts and other instruments executed by such Owner or tenant, and shall enforce the same diligently and in good faith.

14. Release from Liability. Any person acquiring fee or leasehold title to any Parcel shall be bound by this Agreement only as to the rights and obligations pertaining to the Parcel acquired by such person. In addition, such Owner or Lessee shall be bound by this Agreement only during the period such Owner or Lessee is the fee or leasehold owner of such Parcel, except as to obligations, liabilities or responsibilities that accrue during said period. Although persons may be released from liability under this Section, the easements, covenants and restrictions in this Agreement shall continue to be benefits to and servitudes upon said Parcels running with the land and binding upon successors.

15. Remedies; Injunctive Relief. The Parties acknowledge and agree that they have bargained for specific performance of the covenants, conditions, restrictions, rights, and easements contained in this Agreement, and all other provisions hereof, and that each Owner entitled to enforcement of the terms hereof, shall be entitled to seek injunctive relief, including but not limited to temporary restraining orders, preliminary injunctions, and permanent injunctions, both mandatory and prohibitory. Subject to the limitations contained in this Agreement, the Owners shall have all remedies, at law or in equity, in order to enforce the terms of this Agreement. An Owner shall be in default or breach of this Agreement if such Owner fails to perform or cause to be performed any other provision under this Agreement required to be performed by such Owner and such failure is not cured within thirty (30) days after notice to such defaulting Owner or, if such failure cannot be cured within such thirty (30) day period, such defaulting Owner fails within such thirty (30) day period to commence all actions necessary to cure such failure, or after commencing such actions thereafter fails to diligently pursue such actions and cure to completion, but in all events within one hundred twenty (120) days after the delivery of the original default notice by the non-defaulting Owner to the defaulting Owner.

16. Enforcement Proceedings. In the event of a breach of the provisions of this Agreement, the Owner of a Parcel shall be entitled to institute proceedings for full and adequate relief from the consequences thereof. The unsuccessful party in any action shall pay the prevailing party's reasonable attorney's fees, accruing from the date such action was filed, and costs.

17. Election of Remedies; No Waiver. Subject to Section 19, in addition to the rights, powers, and remedies given in this Agreement, the Parties may, in its/their own absolute discretion, at any time, and from time to time, exercise any and all rights and powers, and pursue any and all remedies now or hereafter given at law or in equity, including but not limited to any rights or remedies granted herein or by California or federal case, statutory or regulatory law. Their failure to exercise any such right or remedy shall not be deemed a waiver of that right or remedy unless the Person entitled to that right or remedy has so agreed, expressly and in writing, and the failure to so exercise any right or remedy shall not preclude the Person entitled thereto from later exercising any such right or remedy. Any written waiver of default shall not constitute a continuing waiver or waiver of any other same, similar or different events of default on any future occasion, unless such a waiver of such future defaults is expressed, in writing, with precision. No course of dealing between any person, or any Owner, lessee, or user of any Parcel, or any encumbrance thereof, in exercising any rights under this Agreement shall operate as a waiver of such rights, nor shall any such delay, unless agreed to in writing by the persons entitled to enforce this Agreement, constitute a waiver of any obligation or default. No waiver of default shall extend to or impair any other obligation not expressly waived, nor impair any right

otherwise consequent on such covenant, provision or obligation. Any waiver may be given subject to satisfaction of conditions stated therein. No power or remedy herein conferred is exclusive of or shall prejudice any other power or remedy given by law or by the terms of this Agreement.

18. Rights of Successors; Covenants Running with the Land.

18.1 Rights of Successors. The easements, restrictions, benefits and obligations hereunder shall create mutual benefits and servitudes running with the land. This Agreement shall bind and inure to the benefit of the Owners, their respective heirs, representatives, lessees, successors and assigns. This Agreement shall bind and inure to the benefit of all Owners as provided herein.

18.2 Covenants Running with the Land. The covenants, conditions, restrictions, and easements contained herein shall run with the land, shall constitute equitable servitudes upon each Parcel in favor of the other Parcels, and shall be binding upon and inure to the benefit of the respective successors and assigns of the Owners thereto.

18.3 Benefit to Parcels. Each Owner expressly acknowledges and agrees that the Parcels shall benefit from, and be burdened by, the provisions of this Agreement only as specifically set forth herein. The Owner, Lessee, or user of a Parcel shall not have the right to claim that any right or easement herein granted for the benefit of a Parcel also benefits its Parcel unless such right or easement is expressly granted herein to and for the benefit of such Parcel.

19. Arbitration.

(a) Disputes to be Resolved By Binding Arbitration. The submission of all matters to arbitration in accordance with the terms of this Section is the sole and exclusive method, means, and procedure to resolve any and all claims, disputes, or disagreements arising under this Agreement, except for claims by an Owner which (a) seek anything other than enforcement of rights under this Agreement, or (b) are primarily founded upon matters of fraud, willful misconduct, bad faith, or any other damages, which disputes shall be resolved by suit filed in the Superior Court of the County of Alameda, California, the decision of which court shall be subject to appeal pursuant to applicable law.

(b) Waiver of Right to Litigate. Each Owner hereby irrevocably waives any and all rights to resolve a dispute in a manner which is contrary to the provisions of this Section 19. The Owners shall at all times conduct themselves in strict, full, complete, and timely accordance with the terms of this Section 19 and all attempts to circumvent the terms of this Section 19 shall be absolutely null and void and of no force or effect whatsoever.

(c) Selection of Arbitrator. Any dispute to be arbitrated pursuant to the provisions of this Section 19 shall be determined by binding arbitration before a retired judge of the Superior Court of the State of California (the "**Arbitrator**") under the auspices of Judicial Arbitration & Mediation Services, Inc. ("**JAMS**"). Such arbitration shall be initiated by the Owners, or either of them, within ten (10) days after either Owner sends written notice (the "**Arbitration Notice**") of a demand to arbitrate by registered or certified mail to the other Owner and to JAMS. The

Arbitration Notice shall contain a description of the subject matter of the arbitration, the dispute with respect thereto, the amount involved, if any, and the remedy or determination sought. The Owners shall, within ten (10) days, after the initiation of the arbitration, attempt to agree on a retired judge from the JAMS panel to serve as the Arbitrator. If they are unable to so agree, JAMS will provide a list of three available judges and each party may strike one. The remaining judge (or if there are two, the one selected by JAMS) will serve as the Arbitrator. If JAMS shall no longer exist or if JAMS fails or refuses to accept submission of the dispute, the dispute shall be resolved by binding arbitration before the American Arbitration Association ("AAA") under the AAA's commercial arbitration rules then in effect.

(d) Pre-Decision Arbitration Procedures. The Arbitrator shall schedule a pre-hearing conference to resolve procedural matters, arrange for the exchange of information, obtain stipulations, and narrow the issues. The Owners will submit proposed discovery schedules to the Arbitrator at the pre-hearing conference. The scope and duration of discovery will be within the sole discretion of the Arbitrator. The Arbitrator shall have the discretion to order a pre-hearing exchange of information by the parties, including, without limitation, production of requested documents, exchange of summaries of testimony of proposed witnesses, and examination by deposition of Owners and third-party witnesses. This discretion shall be exercised so as to limit the scope of discovery to the amount of discovery which the Arbitrator determines to be reasonable under the circumstances.

(e) Arbitration Hearing. The arbitration shall be conducted in San Leandro, California. Any Owner may be represented by counsel or other authorized representative. The Owners may offer such evidence as is relevant and material to the dispute. The Arbitrator shall be the judge of relevance and materiality.

(f) Governing Law. In rendering a decision, the Arbitrator shall determine the rights and obligations of the parties according to the substantive and procedural laws of California and the terms and provisions of this Lease.

(g) Arbitration Award. The Arbitrator shall issue the award as soon as reasonably possible following the conclusion of the arbitration hearing, but in no event later than thirty (30) days after the conclusion of the arbitration hearing. The Arbitrator's award shall be based on the evidence introduced at the hearing, including all logical and reasonable inferences therefrom. The Arbitrator may make any determination, and/or grant any remedy or relief that is just and equitable; provided, however, in no event may the Arbitrator award punitive damages. The award must be based on, and accompanied by, a written statement of decision explaining the factual and legal basis for the award as to each of the principal controverted issues. The award shall be conclusive and binding, and it may thereafter be confirmed as a judgment by the Superior Court of the State of California, subject to challenge only (i) on the grounds set forth in California Code of Civil Procedure Section 1286.2, or (ii) based upon the Arbitrator's incorrect application of the substantive laws of California. The validity and enforceability of the Arbitrator's decision is to be determined exclusively by the California courts pursuant to the provisions of this Agreement.

(h) Attorneys' Fees and Costs. The Arbitrator may award costs, including, without limitation, attorneys' fees, and expert and witness costs, to the prevailing party, if any, as

determined by the Arbitrator in the Arbitrator's discretion. The Arbitrator's fees and costs shall be paid by the non-prevailing party as determined by the Arbitrator in his discretion. A party shall be determined by the Arbitrator to be the prevailing party if its proposal for the resolution of dispute is the closer to that adopted by the Arbitrator.

20. Miscellaneous.

20.1 Modification and Cancellation. This Agreement may be amended or canceled only by the mutual written agreement of one hundred percent (100%) of the Owners of all Parcels.

20.2 Integration. This Agreement, together with Exhibits A and B attached hereto and incorporated herein by reference, constitutes the final agreement of the Parties with respect to the subject matter hereof, and supersedes all prior oral and written agreements pertaining thereto, including the drawings referenced in Section 2.1.

20.3 Non-merger. So long as City is an Owner or Lessee of any Parcel, this Agreement shall not be subject to the doctrine of merger.

20.4 Duration. Unless otherwise canceled or terminated, all the easements granted in this Agreement shall continue in perpetuity, and all other rights and obligations hereof shall automatically terminate and be of no further force and effect upon the date that the Garage is demolished.

20.5 No Implied Covenant to Operate. It is expressly agreed by the parties hereto, for their own benefit and that of their successors-in-interest, that no Lessee shall be bound by this Agreement to operate from its premises.

20.6 Headings. The headings herein are inserted only as a matter of convenience and for reference and in no way define, limit or describe the scope or intent of this document nor in any way affect the terms and provisions hereof.

20.7 Notice. Any notice, request, demand, instruction or other communication required to be given hereunder shall be in writing and shall be either (a) personally delivered to the party named below by a commercial messenger service regularly retaining receipts for such delivery, (b) sent by registered or certified mail, return receipt requested, or (c) delivered by recognized air courier services, and such notice shall be effective upon delivery thereof, and shall be addressed to the party as listed below:

City:	City of San Leandro 835 East 14 th Street San Leandro, CA 94577-3767 Attention: City Manager
Chamber:	San Leandro Chamber of Commerce 120 Estudillo Avenue San Leandro, CA 94577

If a Party desires to change its address for the purpose of receipt of notice, such notice or change of address shall be given in the manner specified herein. However, unless and until such written notice of change is actually received, the last address and addressee as stated by written notice, or provided herein if no written notice of change has been received, shall be deemed to continue in effect for all purposes hereunder. This notice provision shall be inapplicable to any judicial or nonjudicial proceeding where California law governs the manner and timing of notice, commencing and prosecuting an action, commencing and prosecuting a foreclosure, or seeking the appointment of a receiver.

20.8 Time of the Essence. Time is of the essence with regard to performance under the terms and provisions of this Agreement, and any amendment, modification or revision thereof, with respect to the actions and obligations of each person bound by the terms hereof. No extension of time for payment of any sum due hereunder shall operate to release, discharge, modify, change, or affect the original liability as established hereunder, either in whole or in part. In accepting an interest in any Parcel, each Owner, lessee, user, mortgagee, and trust deed beneficiary shall be deemed to take its interest knowingly and willingly subject to this time is of the essence clause.

20.9 Severability. Invalidation of any of the provisions contained in this Agreement, or of the application thereof to any Person by judgment or court order, shall in no way affect any of the other provisions hereof or the application thereof to any other Person and the same shall remain in full force and effect.

20.10 Negation of Partnership. None of the terms or provisions of this Agreement shall be deemed to create a partnership between or among the Parties, nor shall it cause them to be considered joint venturers or members of any joint enterprise. No Owner shall have the right to act as an agent for another, unless expressly authorized to do so herein or by separate written instrument signed by the Owner to be charged.

20.11 Not a Public Dedication. Nothing herein contained shall be deemed to be a gift or dedication of any portion of the Property, or of any Parcel or portion thereof to the general public, or for any public use of purpose whatsoever. Except as herein specifically provided, no right, privileges or immunities of any Owner shall inure to the benefit of any third-party person, nor shall any third-party person be deemed to be a beneficiary of any of the provisions contained herein.

20.12 Lessee Obligations. The performance by a Lessee of an Owner's obligations under this Agreement shall satisfy such Owner's obligations hereunder to the extent of such performance with respect to the matter so performed by such Lessee.

20.13 Governing Law. This Agreement has been entered into and executed in the State of California and shall be interpreted in accordance with the laws of said state, excluding, however, the choice of law provisions in regard to conflicts.

20.14 Force Majeure. If an Owner is delayed or hindered in performing any act required hereunder by reason of strikes, lockouts, labor troubles, inability to procure materials, unusually severe weather, terrorism, earthquake, failure of power, restrictive governmental laws or

regulations, riots, insurrection, war or other substantial reason of a similar or dissimilar nature that is beyond such Owner's reasonable control, then the time for performance of such act shall be extended for a period equivalent to the period of such delay (not to exceed 120 days in the aggregate). The Owner delayed or hindered shall promptly notify the other Owner of the event causing the delay or hindrance. The foregoing shall not excuse any Owner from securing necessary financing or from making any payments due under this Agreement.

20.15 Attorneys' Fees. If there is any legal action or proceeding to enforce or interpret any provision of this Agreement or to protect or establish any right or remedy of any party, the unsuccessful party to such action or proceeding shall pay to the prevailing party as finally determined all costs and expenses, including attorneys' fees and costs, incurred by such prevailing party in such action or proceeding, in enforcing such judgment, and in connection with any appeal from such judgment. Attorneys' fees and costs incurred in enforcing any judgment or in connection with any appeal shall be recoverable separately from and in addition to any other amount included in such judgment. This Section is intended to be severable from the other provisions of this Agreement, and the prevailing party's rights under this Section shall not merge into any judgment and this Section and any judgment shall survive until all such fees and costs have been paid.

20.16 No Third Party Beneficiaries. Except as herein specifically provided, no rights, privileges or immunities conferred on the Owners by this Agreement shall inure to the benefit of any third party; nor shall any third party be deemed to be a third party beneficiary of any of the provisions contained herein.

20.17 Further Assurances. Each Owner shall execute such other and further documents and instruments reasonably requested by the other Owner (so long as it owns fee title to any Parcel) to more clearly evidence and carry out the provisions of this Agreement.

20.18 Counterparts. This Agreement may be executed in counterparts, each of which shall be an original and all of which taken together shall constitute one and the same agreement.

20.19. Estoppel Certificates. Any Owner (the "**Certifying Party**") shall at any time and from time to time upon not less than ten (10) days' prior written notice from the other Owner (the "**Requesting Party**"), execute, acknowledge, and deliver to the Requesting Party a statement in writing, as requested by the Requesting Party or any current or prospective purchaser, assignee, Lessee or lender of all or any portion of the Requesting Party's certifying: (a) that this Agreement and the applicable easements created hereby are unmodified and in full force and effect (or, if modified, adequately identifying such modification and certifying that this Agreement and such easements as so modified are in full force and effect), (b) whether or not to the knowledge of the Certifying Party there is any material default by the Requesting Party in the performance of any term, covenant, condition, provision or agreement contained in this Agreement and further whether or not there are any setoffs, defenses or counterclaims against enforcement of the obligations to be performed under this Agreement and, if there are, specifying each such material default, setoff, defense or counterclaim, and (c) such other matters as the Requesting Party may reasonably request in writing. Any such statement may be relied upon by any such prospective purchaser, assignee, Lessee or lender of a Parcel. The Certifying Party's failure to deliver such statement within such time shall be deemed a statement that this

Agreement is in full force and effect, without modification except as may be represented by the Requesting Party in such request, and that there are no uncured material defaults in Certifying Party's or Requesting Party's or any other party's performance. If a particular Requesting Party requests more than one such statement from a particular Certifying Party per calendar year, such Certifying Party shall be entitled to charge such Requesting Party a reasonable fee to cover its administrative costs in preparing such statement

SIGNATURE(S) ON FOLLOWING PAGE(S).

IN WITNESS WHEREOF, the Parties have executed this Agreement as of the date first written above.

CITY

By: _____

Name: _____

Its: _____

Attest: _____

APPROVED AS TO FORM:

City Attorney

~~CHAMBER~~

By:  _____

Name: David P. Johnson

Its: President & CEO

By:  _____

Name: David Grodin

Its: Chair, Board of Directors

CALIFORNIA ALL-PURPOSE ACKNOWLEDGMENT

State of California

County of Alameda

On 3/11/13 before me, Tara H. Peterson, Notary Public

personally appeared David P. Johnson and David Grodin

who proved to me on the basis of satisfactory evidence to be the person(s) whose name(s) is/are subscribed to the within instrument and acknowledged to me that he/she/they executed the same in his/her/their authorized capacity(ies), and that by his/her/their signature(s) on the instrument the person(s), or the entity upon behalf of which the person(s) acted, executed the instrument.



I certify under PENALTY OF PERJURY under the laws of the State of California that the foregoing paragraph is true and correct.

WITNESS my hand and official seal.

Signature Tara Peterson
Signature of Notary Public

Place Notary Seal Above

OPTIONAL

Though the information below is not required by law, it may prove valuable to persons relying on the document and could prevent fraudulent removal and reattachment of this form to another document.

Description of Attached Document

Title or Type of Document: Reciprocal Escrowment Agreement and Delegation of CC&Rs

Document Date: 3/11/13 Number of Pages: 25

Signer(s) Other Than Named Above: _____

Capacity(ies) Claimed by Signer(s)

Signer's Name: _____

- Individual
- Corporate Officer — Title(s): _____
- Partner — Limited General
- Attorney in Fact
- Trustee
- Guardian or Conservator
- Other: _____

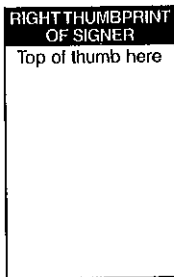

Signer is Representing: _____

Signer's Name: _____

- Individual
- Corporate Officer — Title(s): _____
- Partner — Limited General
- Attorney in Fact
- Trustee
- Guardian or Conservator
- Other: _____

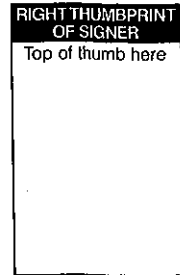

Signer is Representing: _____

EXHIBIT A

PARCEL MAP 10073

BEING A SUBDIVISION OF THOSE PARCELS OF LAND DESCRIBED IN THAT CERTAIN GRANT DEED RECORDED JUNE 13, 1972 ON REEL 3155 AT PAGE 371, AND THAT CERTAIN GRANT DEED RECORDED JUNE 6, 1987 UNDER INSTRUMENT NO. 87152847, ALL OFFICIAL RECORDS OF ALAMEDA COUNTY.

CITY OF SAN LEANDRO - ALAMEDA COUNTY - CALIFORNIA
JANUARY 2013

KIER & WRIGHT
CIVIL ENGINEERS & SURVEYORS, INC.
2550 S. BRIDGEMAN AVE., SUITE 100
SAN LEANDRO, CALIFORNIA 94577
TEL: (925) 344-8778

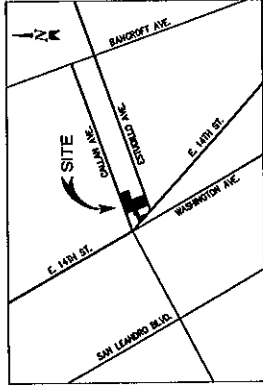

VICINITY MAP
NOT TO SCALE

OWNER'S STATEMENT.
THE UNDERSIGNED HEREBY STATES THAT HE IS THE OWNER OF THE LAND DELINEATED AND DESCRIBED WITHIN THE REFERENCED BOUNDARY LINES ON THE HEREBY ENCLOSED PARCEL MAP ENTITLED "PARCEL MAP NO. 10073," THAT SAID OWNER CONSENTS TO THE PREPARATION AND FILING OF THIS MAP.

THIS MAP SHOWS ALL THE EASEMENTS ON THE PREMISES, OR OF RECORD, OF THE CITY OF SAN LEANDRO, A MUNICIPAL CORPORATION

BY: _____ DATE _____
ITS: _____

OWNER'S ACKNOWLEDGEMENT:
STATE OF CALIFORNIA)
COUNTY OF _____) SS.
ON _____ 20____ BEFORE ME
(HERE INSERT NAME AND TITLE OF THE OFFICER)

PERSONALLY APPEARED _____ WHO PROVED TO ME ON THE BASIS OF SATISFACTORY EVIDENCE TO BE THE PERSON(S) WHOSE NAME(S) IS/ARE SUBSCRIBED TO THE WITHIN INSTRUMENT AND ACKNOWLEDGED TO ME THAT HE/SHE/IT/HEY EXECUTED THE SAME IN HIS/HER/ITS AUTHORIZED CAPACITY(IES), AND THAT THE INSTRUMENT(S) WERE THE ACTED, EXECUTED AND SIGNED BY THE PERSON(S) ON THE CITY UPON BEHALF OF WHICH THE PERSON(S) ACTED, EXECUTED AND SIGNED THE INSTRUMENT(S).

I HEREBY UNDER PENALTY OF PERJURY UNDER THE LAWS OF THE STATE OF CALIFORNIA, THAT THE FOREGOING PARAGRAPH IS TRUE AND CORRECT.

WITNESS MY HAND.
SIGNATURE: _____
PRINTED NAME: _____
COMMISSION NUMBER: _____
COMMISSION EXPIRES: _____
PRINCIPAL PLACE OF BUSINESS: _____ COUNTY _____

SURVEYOR'S STATEMENT.
THIS MAP WAS PREPARED BY ME OR UNDER MY DIRECTION AND IS BASED UPON A FIELD SURVEY IN CONFORMANCE WITH THE REQUIREMENTS OF THE SURVEYOR MAP ACT AND LOCAL ORDINANCE AT THE REQUEST OF THE CITY OF SAN LEANDRO IN OCTOBER 2011. I HEREBY STATE THAT THIS PARCEL MAP SUBSTANTIALLY COMPLIES WITH THE APPROVED OR CONDITIONALLY APPROVED REQUIREMENTS OF THE SURVEYOR MAP ACT AND THAT THE MAP IS APPROVED OR CONDITIONALLY APPROVED AND IS SUBJECT TO THE PROVISIONS OF THE SURVEYOR MAP ACT AND LOCAL ORDINANCE. SHORT AND OCCUPY THE POSITIONS INVOLVED AND ARE AUTHORIZED TO ENABLE THE SURVEY TO BE RETRACED.



KEITH WARDLE, P.E., THIS
LICENSE EXPIRES: 12-31-2013
DATE _____

CITY SURVEYOR'S STATEMENT.
I, FRANK C. BELLEZ, CITY SURVEYOR FOR THE CITY OF SAN LEANDRO, DO HEREBY STATE THAT I HAVE EXAMINED THE HEREBY ENCLOSED PARCEL MAP ENTITLED "PARCEL MAP NO. 10073" CONSISTING OF THREE (3) SHEETS. THIS STATEMENT BEING ON SHEET ONE (1) THEREOF, AND THAT THE SURVEY DATA SHOWN UPON SAID MAP IS GENERALLY CORRECT.

FRANK C. BELLEZ, L.S. NO. 3399
CITY SURVEYOR FOR THE CITY OF SAN LEANDRO,
ALAMEDA COUNTY, CALIFORNIA
DATE _____

CITY ENGINEER'S STATEMENT.
I, ROBERT JOSEPH, CITY ENGINEER OF THE CITY OF SAN LEANDRO, COUNTY OF ALAMEDA, STATE OF CALIFORNIA, DO HEREBY STATE AS FOLLOWS:
1) THAT I HAVE EXAMINED THE HEREBY ENCLOSED PARCEL MAP ENTITLED "PARCEL MAP NO. 10073," CONSISTING OF THREE (3) SHEETS. THIS STATEMENT BEING ON SHEET ONE (1) THEREOF.
2) THE SUBDIVISION AS SHOWN UPON SAID PARCEL MAP IS SUBSTANTIALLY THE SAME AS SAID SUBDIVISION APPEARED ON THE REFERENCED MAP, IF REFERRED, AND ANY APPROVED ALTERATION THEREOF.
3) ALL PROVISIONS OF THE SURVEYOR MAP ACT OF THE STATE OF CALIFORNIA AND ALTERNATE PROVISIONS THEREOF ARE FULLY COMPLIABLE AT THE TIME OF APPROVAL OF THE REFERENCED MAP, IF REFERRED, HAVE BEEN COMPLIED WITH.

IN WITNESS WHEREOF, I HAVE HEREBY SET MY HAND THIS _____ DAY OF _____ 20____

ROBERT JOSEPH, P.E., THIS
LICENSE EXPIRES: 12-31-2013
DATE _____

RECERTIFICATE OF CLERK OF BOARD OF SUPERVISOR.
I, CHERYL PERROS, ASSISTANT CLERK OF THE BOARD OF SUPERVISORS FOR THE COUNTY OF ALAMEDA, STATE OF CALIFORNIA, DO HEREBY CERTIFY, AS CHECKED BELOW THAT:
 AN APPROVED BOND HAS BEEN FILED WITH THE SUPERVISORS OF THE SAID COUNTY AND SAID IN THE AMOUNT OF \$_____, CONDITIONED FOR PAYMENT OF ALL TAXES AND SPECIAL ASSESSMENTS COLLECTED AS TAXES WHICH ARE NOW A LIEN AGAINST SAID LAND OF ANY PART THEREOF BUT NOT YET PAYABLE, AND WAS DULY APPROVED BY SAID BOARD IN SAID AMOUNT.
 ALL TAXES AND SPECIAL ASSESSMENTS COLLECTED AS TAXES HAVE BEEN PAID AS CERTIFIED BY THE TREASURER TAX COLLECTOR OF THE COUNTY OF ALAMEDA.

CHERYL PERROS, ASSISTANT CLERK OF THE BOARD OF SUPERVISORS FOR THE COUNTY OF ALAMEDA, STATE OF CALIFORNIA
DATE _____

BY: _____ DEPUTY CLERK

CITY CLERK'S STATEMENT.
I, MARION HANRA, CITY CLERK AND CLERK OF THE COUNCIL OF THE CITY OF SAN LEANDRO, COUNTY OF ALAMEDA, STATE OF CALIFORNIA, DO HEREBY STATE THAT THE HEREBY ENCLOSED "PARCEL MAP NO. 10073," CONSISTING OF THREE (3) SHEETS, THIS STATEMENT BEING ON SHEET 1 THEREOF, WAS PRESENTED TO SAID COUNCIL OF THE CITY OF SAN LEANDRO AS PROVIDED BY LAW, AT A REGULAR MEETING HELD ON THE _____ DAY OF _____, 20____, AND THAT SAID COUNCIL OF THE CITY OF SAN LEANDRO DO THEREUPON BY RESOLUTION NUMBER _____ DULY PASSED AND ADOPTED AT SAID MEETING, APPROVE SAID MAP.
IN WITNESS WHEREOF, I HAVE HEREBY SET MY HAND THIS _____ DAY OF _____ 20____

MARION HANRA
CITY CLERK AND CLERK OF THE CITY COUNCIL
OF THE CITY OF SAN LEANDRO,
STATE OF CALIFORNIA

RECORDER'S STATEMENT.
FILED THIS _____ DAY OF _____ 20____ AT _____ AT THE REQUEST OF _____ IN BOOK _____ OF PARCEL MAPS, AT PAGE _____ AT THE REQUEST OF OLD REPUBLIC TITLE COMPANY.

FILE: _____ SERIES NUMBER: _____
COUNTY RECORDED IN AND FOR THE COUNTY OF ALAMEDA, STATE OF CALIFORNIA

BY: _____ DEPUTY COUNTY RECORDER

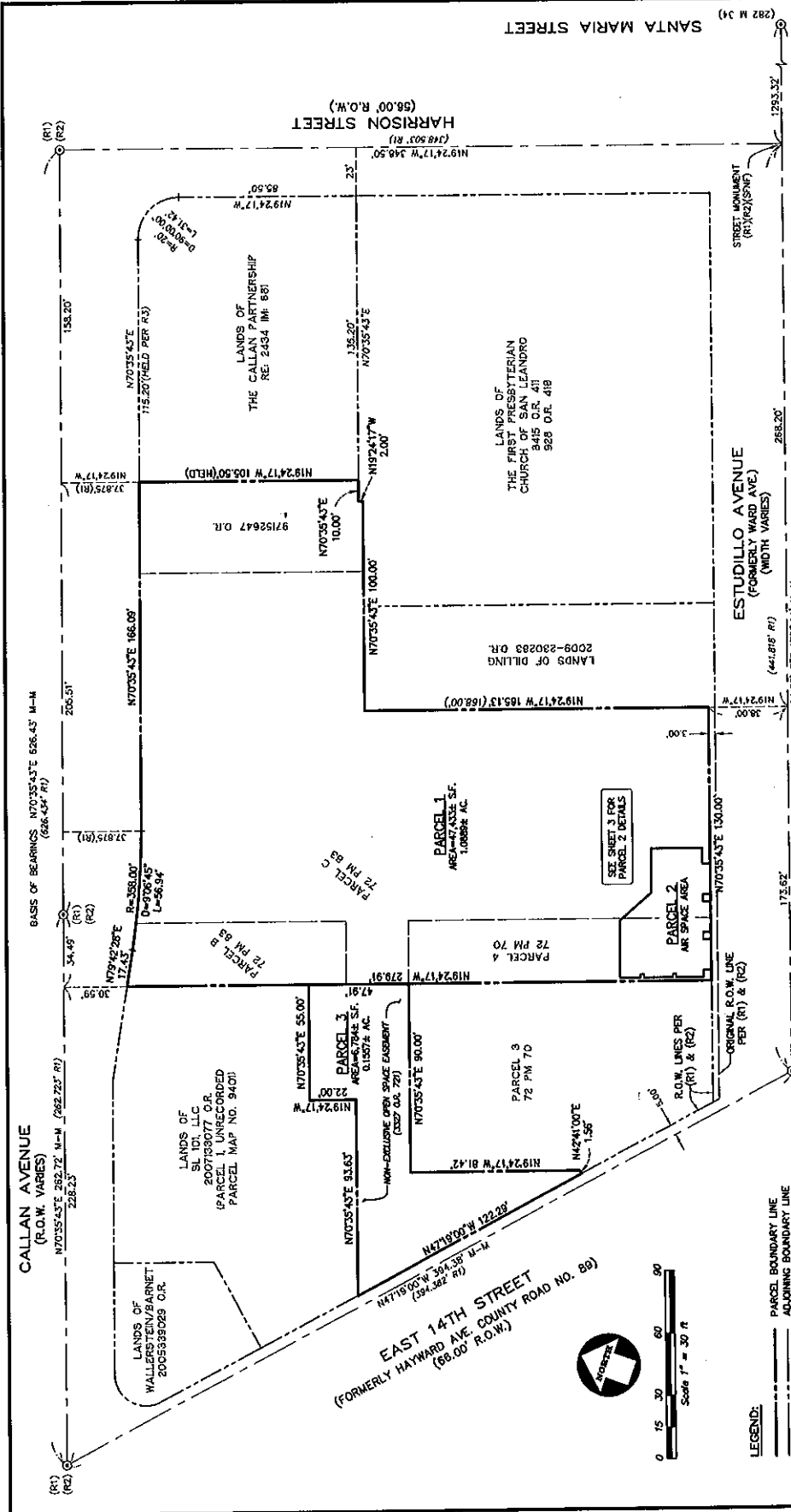

PARCEL MAP 10073

BEING A SUBDIVISION OF THOSE PARCELS OF LAND DESCRIBED IN THAT CERTAIN GRANT DEED RECORDED JUNE 13, 1972 ON REEL 3153 AT PAGE 311, AND THAT CERTAIN GRANT DEED RECORDED JUNE 6, 1997 UNDER INSTRUMENT NUMBER 97152847, ALL OFFICIAL RECORDS OF ALAMEDA COUNTY.

CITY OF SAN LEANDRO - ALAMEDA COUNTY - CALIFORNIA
 JANUARY 2013

KIER & WRIGHT
 CIVIL ENGINEERS & SURVEYORS, INC.
 2500 Collier Center Blvd.
 Fremont, California 94538
 Phone (925) 245-8778
 Fax (925) 245-8779

JOB NO. AL1574-1
 SHEET 2 OF 3 SHEETS

BASES OF BEARINGS:
 FOUND MONUMENTS IN CALLAN AVENUE AS SHOWN ON PARCEL MAP NO. 902 FILED MAY 2, 1972 IN BOOK 72 OF PARCEL MAPS AT PAGE 83 TAKEN AS NORTH 70° 35' 45" EAST IS THE BASIS OF BEARINGS SHOWN HEREON.
 CITY BENCHMARK:
 A CHCH NAIL IN THE TOP OF CATCH BASIN ON THE NORTHEASTERLY CORNER OF CALLAN AVENUE AND EAST 14th STREET, ELEVATION = 55.965' (NOV2008)

NOTE:
 PARCEL 3 IS AFFECTED BY A 10 FOOT WIDE EASEMENT, RECORDED MAY 1, 2008, UNDER SERIES NO. 2008174310, THE LOCATION OF SAID EASEMENT IS NOT DEFINED IN SAID DOCUMENT AND IS NOT PLOTTED HEREON.

- LEGEND:**
- PARCEL BOUNDARY LINE
 - ADJOINING BOUNDARY LINE
 - OLD LOT LINE
 - MONUMENT LINE
 - FOUND STREET MONUMENT, AS NOTED
 - RECORD DATA
 - () MONUMENT-TO-MONUMENT
 - () MONUMENT-TO-MONUMENT LINE
 - () PARCEL MAP
 - () RIGHT-OF-WAY
 - () SEARCHED FOR NOT FOUND
 - () SQUARE FEET

MAP REFERENCE:
 (R1) PARCEL MAP NO. 902, 72 PM 83
 (R2) P.O.S. 457, 8 P.O.S. 57
 (R3) 89-58383 O.R.

DETAIL OF PARCEL 2
SCALE: 1" = 10'

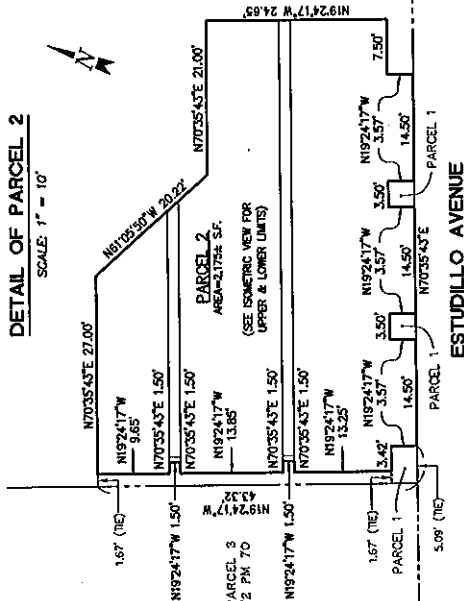

PARCEL 2
ISOMETRIC VIEW
NOT TO SCALE

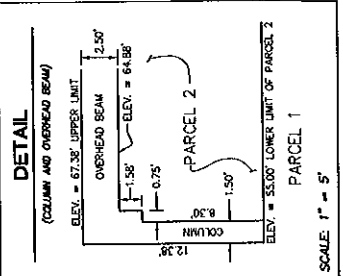
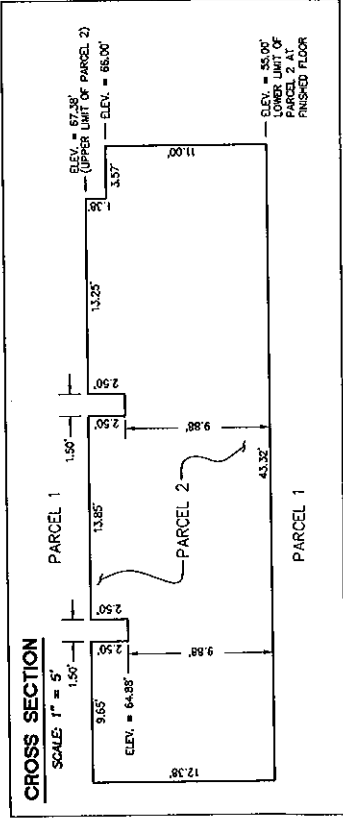
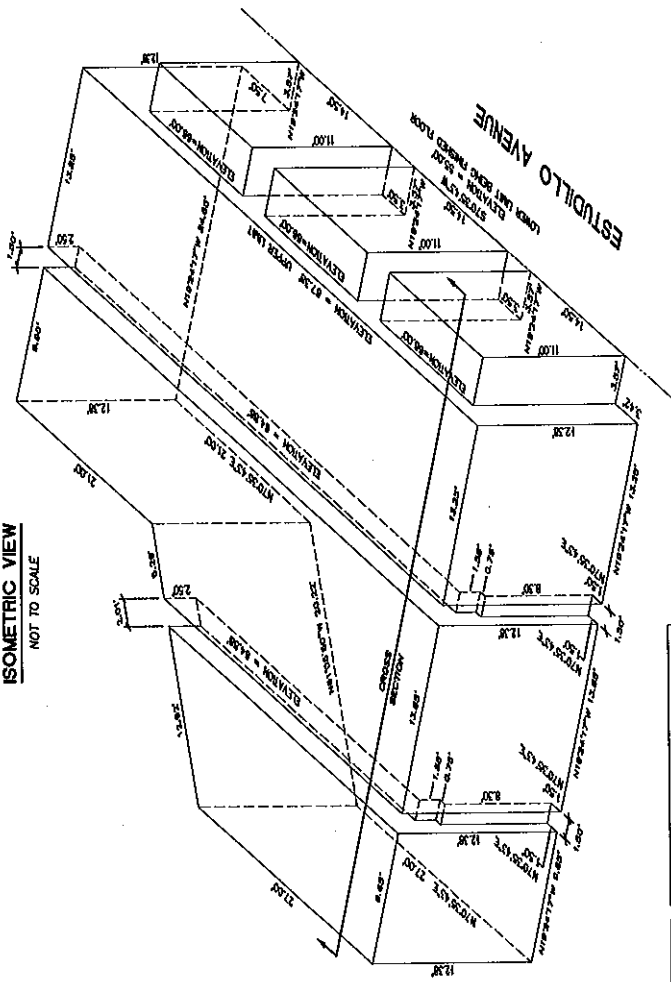

PARCEL MAP 10073

BEING A SUBDIVISION OF THOSE PARCELS OF LAND DESCRIBED IN THAT CERTAIN GRANT DEED
RECORDED JUNE 13, 1972 ON REEL 3155 AT PAGE 371, AND THAT CERTAIN GRANT DEED
RECORDED JUNE 6, 1997 UNDER RECORD NUMBER 97165047, ALL ORIGINAL RECORDS OF
ALAMEDA COUNTY.

CITY OF SAN LEANDRO - ALAMEDA COUNTY - CALIFORNIA

JANUARY 2013
KIER & WRIGHT
CIVIL ENGINEERS & SURVEYORS, INC.
2500 California Street, Suite 200
Emeryville, California 94608 Tel: (925) 246-0700

SHEET 3 OF 3 SHEETS
JOB NO. A11574-1

EXHIBIT B

LEGAL DESCRIPTIONS OF PARCEL

Waste Room

Mechanical Equipment Area

Parking Spaces

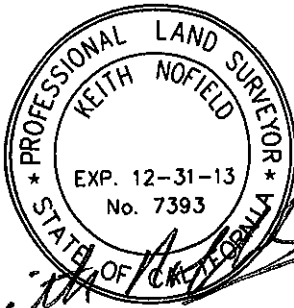

INDEX SHEET

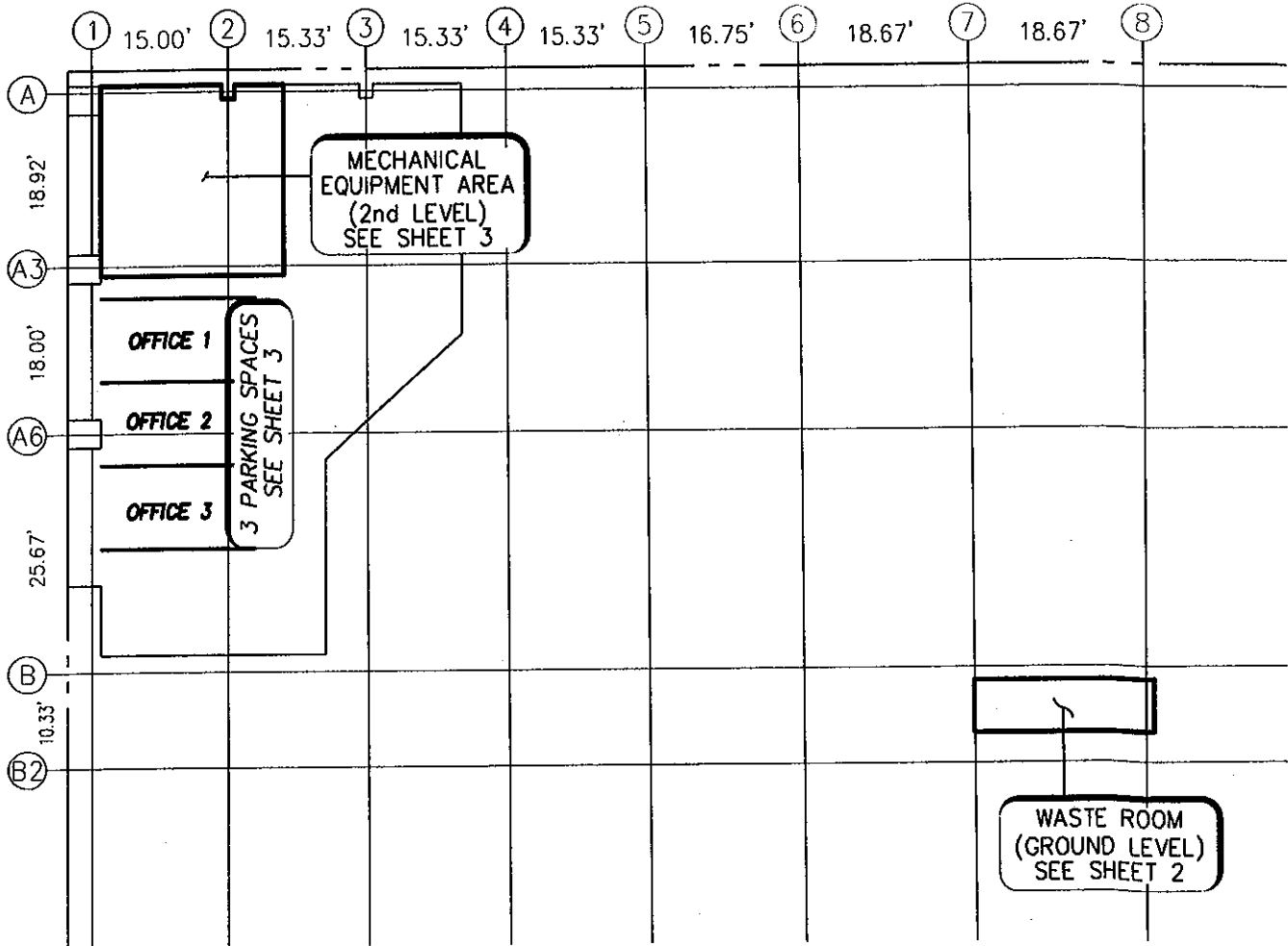
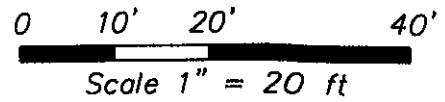

KIER & WRIGHT
 CIVIL ENGINEERS & SURVEYORS, INC.
 2850 Collier Canyon Road Phone (925) 245-8788
 Livermore, California 94551 Fax (925) 245-8796

EXHIBIT "B" INDEX KEY SHEET

SAN LEANDRO, ALAMEDA COUNTY, CALIFORNIA

SCALE	1" = 20'
DATE	DEC. 2012
BY	KN/CH
JOB NO.	A11574-1
SHEET	1 OF 3

LEGEND

- F.F. FINISH FLOOR
- ① GRIDLINES PER "CITY PLANS" REFERENCED IN SECTION 2.1

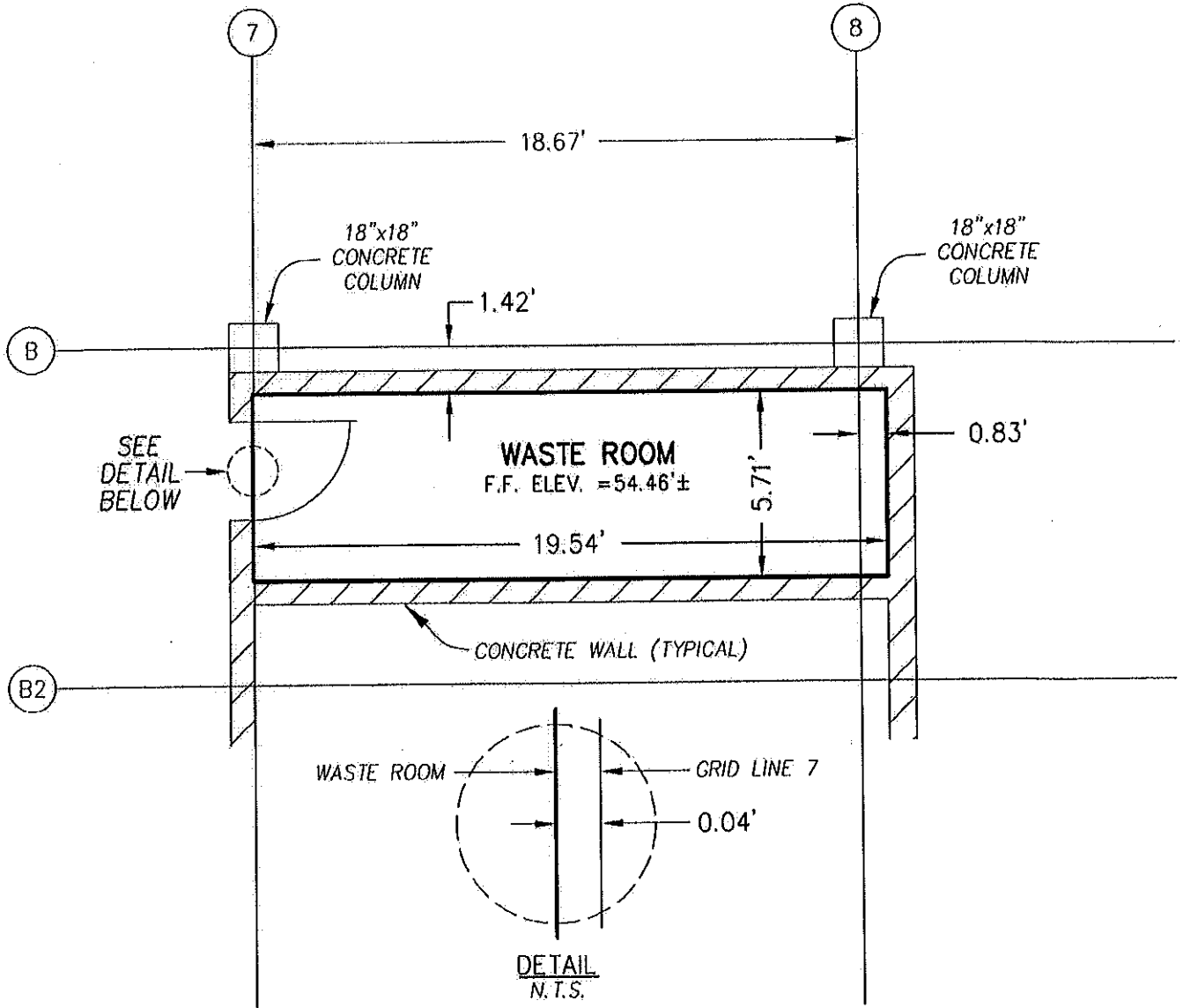
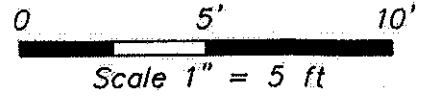

KIER & WRIGHT
 CIVIL ENGINEERS & SURVEYORS, INC.
 2850 Collier Canyon Road Phone (925) 245-8788
 Livermore, California 94551 Fax (925) 245-8796

EXHIBIT "B"
WASTE ROOM

SAN LEANDRO, ALAMEDA COUNTY, CALIFORNIA

SCALE	1" = 5'
DATE	DEC. 2012
BY	KN/CH
JOB NO.	A11574-1
SHEET	2 OF 3

LEGEND

- PROPERTY LINE
- X- FENCE
- CC CONCRETE COLUMN
- FF FINISH FLOOR
- ① GRIDLINES PER "CITY PLANS" REFERENCED IN SECTION 2.1

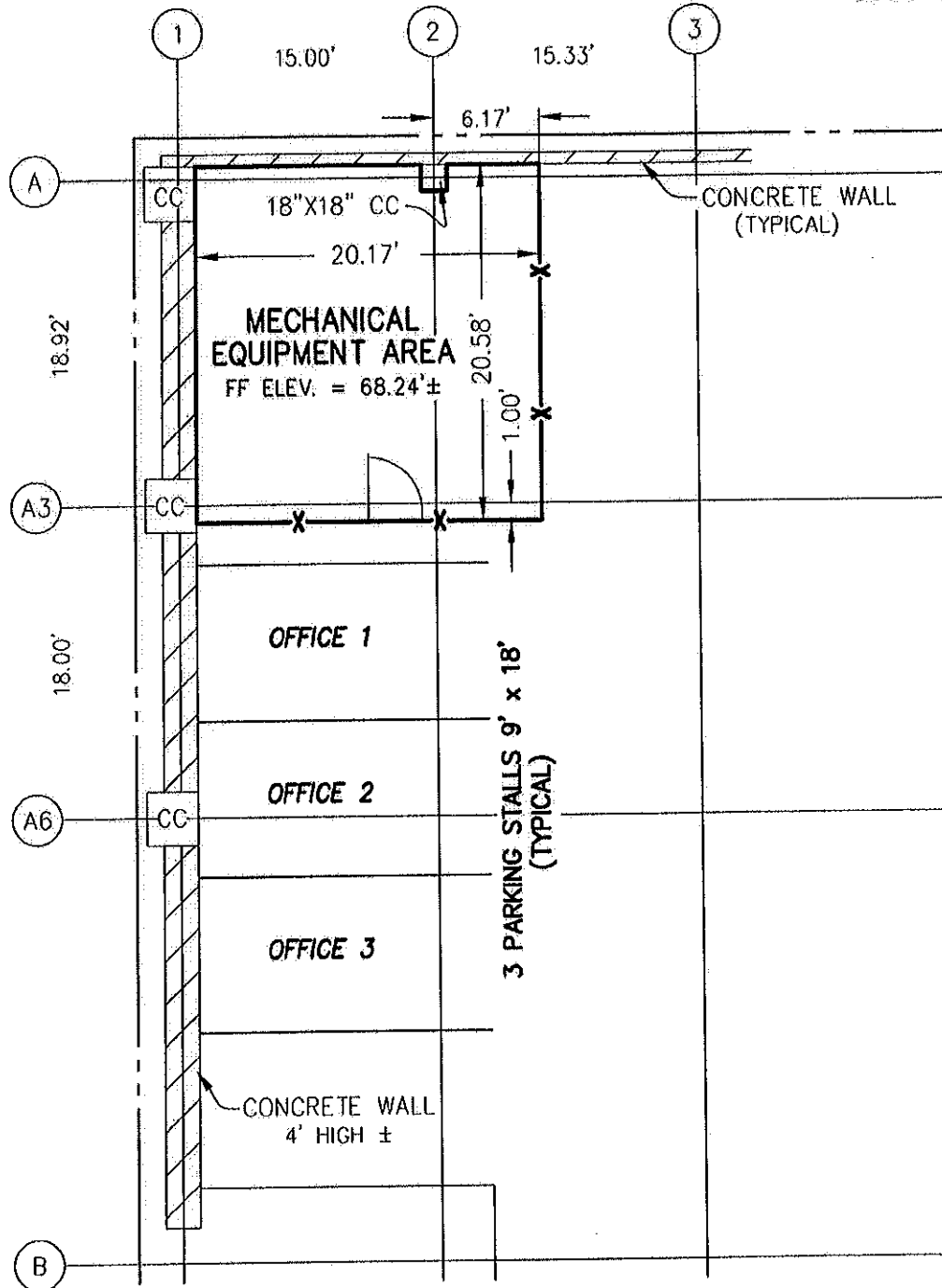
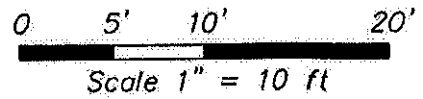

KIER & WRIGHT
 CIVIL ENGINEERS & SURVEYORS, INC.
 2850 Collier Canyon Road Phone (925) 245-8788
 Livermore, California 94551 Fax (925) 245-8796

EXHIBIT "B"
OFFICE
PARKING AND MECHANICAL
EQUIPMENT AREA

SAN LEANDRO, ALAMEDA COUNTY, CALIFORNIA

SCALE	1" = 10'
DATE	DEC. 2012
BY	KN/CH
JOB NO.	A11574-1
SHEET	3 OF 3

EXHIBIT C

2030289.1

LEGEND

- PROPERTY LINE
- CC CONCRETE COLUMN (3' X 3')
- ⊥ PROPERTY LINE
- ① GRIDLINES PER "CITY PLANS" REFERENCED IN SECTION 2.1

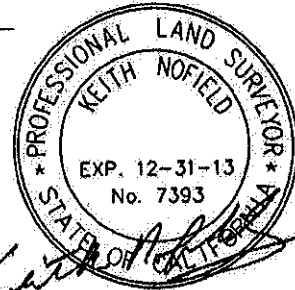
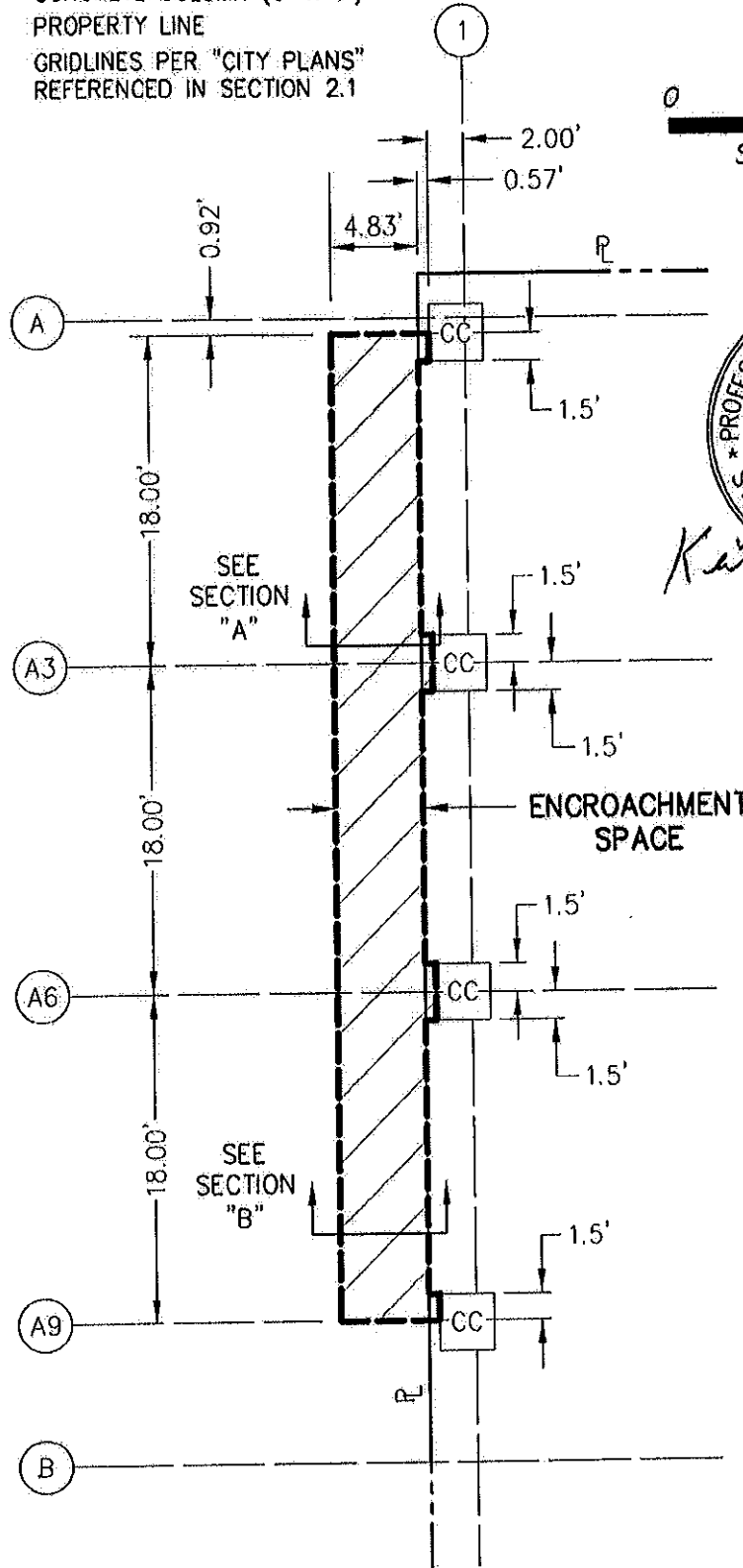

KIER & WRIGHT
 CIVIL ENGINEERS & SURVEYORS, INC.
 2850 Collier Canyon Road Phone (925) 245-8788
 Livermore, California 94551 Fax (925) 245-8796

EXHIBIT "C"
LOUVER AND SIGNAGE
ENCROACHMENT

SAN LEANDRO, ALAMEDA COUNTY, CALIFORNIA

SCALE	1" = 10'
DATE	JAN. 2013
BY	KN/CH
JOB NO.	A11574-1
SHEET	1 OF 2